

SWMP 4K Seamless Modular Video Wall Matrix Switchers User Guide

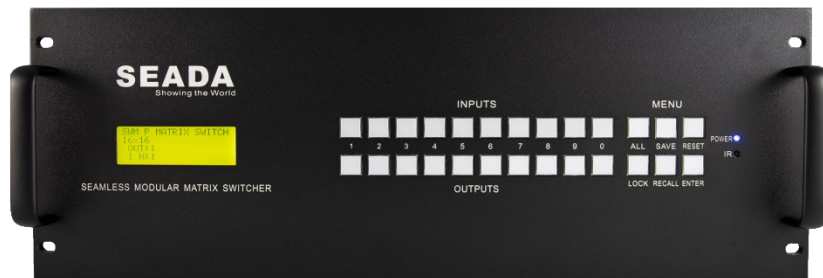

Up/Down
Scaling

Video Wall

Multi
Formats

Seamless
Switching

Modular
Design

Redundant
PSUs

Document No. SD-MA-039

Document Version: 03

Table of Contents

1. Product Introduction	2
1.1. Product profile	2
1.2. Product capability	2
1.3. Specification & Parameters	3
2. Hardware Overview (2U)	4
2.1. Front Panel	4
2.2. Rear Panel (2U)	4
3. Connection Set up	5
3.1. RS232 connection.....	5
3.2. Ethernet Connection.....	5
4. SWMP Software User Guide.....	5
4.1. Matrix Switch	7
4.2. Signal setting	9
4.3. PQ & Position	10
4.4. Video Wall	11
4.5. Network Setting	13
5. Remote Control	14
5.1. Output/Input Buttons.....	14
5.2. Function Buttons.....	14
6. SWMP ASCII Command Lines	15
6.1. Video switching.....	15
6.2. Save Video Wall/Matrix Preset Layout	15
6.3. Load Video Wall/Matrix Preset Layout.....	15

1. Product Introduction

1.1. Product profile

- SWMP multi format 4K Seamless Modular Video Wall Matrix Switcher is a high-performance video signal switching equipment, can support up to 80 inputs, 80 outputs, with inserting plate structure. This product supports multiple video formats input and output, switching, without disturbing the other output, high performance output.
- Multi format matrix using the insert plate structure, flexible and convenient installation. Support UHD-HDMI, 4K HDBaseT, 4K Fiber Optica, HDMI, DVI-U, SDI and VGA input/output daughter cards. At the same time, with the Ethernet and RS232 communication interface, through the special control software to control the matrix signal switching, monitoring the working state of the matrix, set the signal resolution, etc.
- DVI-U daughter card support HDMI/DVI/VGA/YPbPr/CVBS signal with different terminal adapters
 - So, for an HDMI signal, we can use HDMI card directly or DVI-U card, for VGA signal, we can use VGA (DB15 interface) card directly or DVI-U card
- Seamless switching available.
- Video wall function available.

1.2. Product capability

- Support HDBaseT, HDMI, DVI-U, SDI, VGA, UHD-HDMI, Fiber Optic cards.
- Support a maximum resolution of 1600 x 1200@60hz with normal card.
- Support a maximum resolution of 3840 x 2160@60hz with 4K card.
- Provide a variety of control interface: RS232, Ethernet, WebUI.
- Provide control software to facilitate remote control, real-time display the input and output status.
- Scalar inside, output resolution control available.
- Support Seamless switching, Character overlay, Video Wall function.

1.3. Specification & Parameters

1080P Input & Output cards				
Input	Interface type	Signal	Format	
	DVI-U	HDMI DVI VGA YPbPr CVBS	HDMI / DVI / VGA: 800x600,1024x768,1280x768,1280x800,1280x1024,1360x768,1400x1050,1600x1200,1920x1080 YPbPr: 576i50,720p50,720p60,1080i50,1080i60, 1080p50,1080p60 CVBS: PAL, NTSC	
	HDMI	HDMI	Same as DVI-U (HDMI input)	
	VGA	VGA	Same as DVI-U (VGA input)	
	BNC	SDI	480i60,576i50,1080i60,1080i50,720p60,720p50,1080p24/25/30/50/60	
	RJ45	HDBaseT	Same as DVI-U (HDMI input)	
	LC	Fiber	Single mode single Fiber, 1920x1080, up to 1.4Km or 20Km	
	Output	Interface type	Signal	Format
DVI-U		HDMI DVI VGA YPbPr CVBS	HDMI / DVI / VGA: 1024x768, 1280x1024, 1360x768, 1280x720, 1600x1200 ,1680x1050, 1920x1080 YPbPr: 1080p60, 720p60 CVBS: PAL, NTSC	
HDMI		HDMI	Same as DVI-U (HDMI output)	
VGA		VGA	Same as DVI-U (VGA output)	
BNC		SDI	576i50,480i59,720p50,720p60,1080i50,1080i59,1080i60,1080p24/25/29/30/50/60	
RJ45		HDBaseT	Same as DVI-U (HDMI output)	
LC		Fiber	Single mode single Fiber, 1920x1080, up to 1.4Km or 20Km	
4K Input & Output Cards				
Input	Interface type	Signal	Format	
	HDMI	HDMI	Up to HDMI 2.0 4K 444@60Hz	
	RJ45	HDBaseT	4K@60Hz, works with HDBaseT seamless transmitter box. Each card needs 24V external power supply to PoC up to 2 x HDBaseT TX	
	LC	Fiber	4K@60Hz, works with Fiber seamless transmitter box.	
Output	Interface type	Signal	Format	
	HDMI	HDMI	Up to HDMI 2.0 4K 444@60Hz	
	RJ45	HDBaseT	4K@60Hz, works with HDBaseT seamless receiver box. Each card needs 24V external power supply to PoC up to 2 x HDBaseT RX	
	LC	Fiber	4K@60Hz, works with Fiber seamless receiver box.	
Control -RS232		RS-232 Straight	D-sub-9	Baud rate : 9600
Control -LAN		Static IP, Automatic IP		
Power supply		AC100 - 240V 50/60Hz		
Working temperature		32 - 104°F / 0 - 40°C		
Storage temperature		-4 - 140°F / -20 - 60°C		
Humidity		20 - 90% RH (no condensation)		
	8x8, 2U	16x16, 4U	36x36, 8U	80x80, 16U
Dimension W*D*H	483x365x89mm	483x365x178mm	483x365x356mm	483x365x712mm
Gross weight	9Kg	13Kg	23Kg	44Kg
Power Supply	100W * 2 (Redundant)	200W * 2 (Redundant)	350W * 2 (Redundant)	350W * 4 (Redundant)

2. Hardware Overview (2U)

2.1. Front Panel

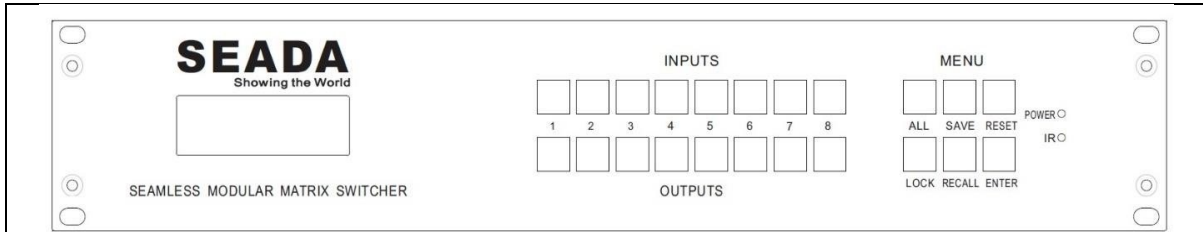

- **OUTPUT/INPUT Buttons**

Press buttons **OUTPUT x + INPUT y + ENTER** in order, switch input **x** to output **y**.

- **MENU Buttons**

- Press buttons **ALL + INPUT x + ENTER** in order, to switch input **x** to all the outputs, users can use this combination to switch between different inputs to the video wall
- Press buttons **SAVE + OUTPUT y + ENTER** to save current matrix/video wall layout as layout **y** (Save up to 8 preset layouts using panel buttons)
- Press buttons **RECALL + OUTPUT y + ENTER** in order, to recall layout **y** (Recall up to 8 preset layouts using panel buttons)
- Press **RESET** button to cancel the current command function
- Press **LOCK** button to lock all front panel buttons
- **ENTER** button is an executive key

2.2. Rear Panel (2U)

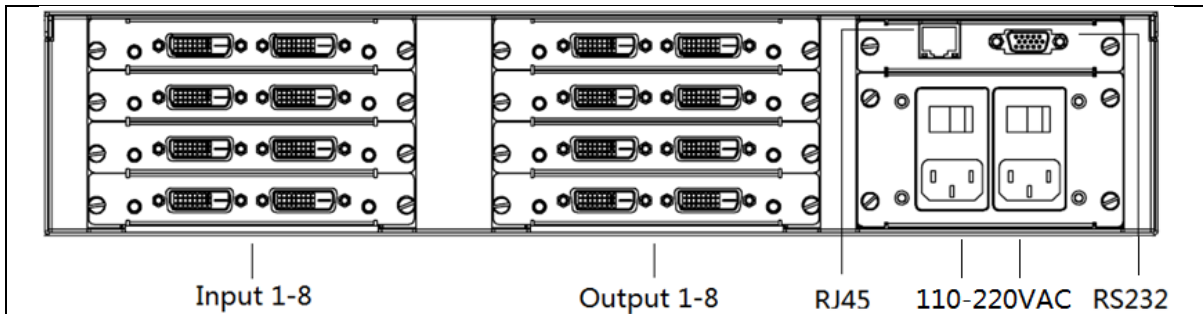

- **LAN(10M/100M/1000M) and RS232 Port are for PC control**

- **Input Ports**

Up to 80 inputs (16U) of different formats (DVI, HDMI, SDI, HDBaseT and Fiber) with resolution up to 4K@60

- **Out Ports**

Up to 80 outputs (16U) of different formats (DVI, HDMI, SDI, HDBaseT and Fiber) with resolution up to 4K@60

- **Power Supply Socket**

110 ~ 240 VAC redundant power supplies

3. Connection Set up

3.1. RS232 connection

RS-232 control, baud rate 9600, DB9 connector

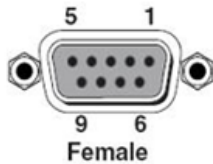

3.2. Ethernet Connection

Connect the SWMP unit with the control PC using either CAT cable. Make sure the PC is in the same group of static IP address as SWMP.

IP Type	Static IP
Static IP	192 . 168 . 0 . 247
Subnet Mask	255 . 255 . 255 . 0
Gateway	192 . 168 . 0 . 1

Left is the default IP setting of SWMP. Users can change the IP address once connected.

4. SWMP Software User Guide

Users can run the SWMP.exe software directly without installation. Software is on the disk in the package, or you can download it from the SEADA website. Double click the SWMP software to get the Dialog box as below

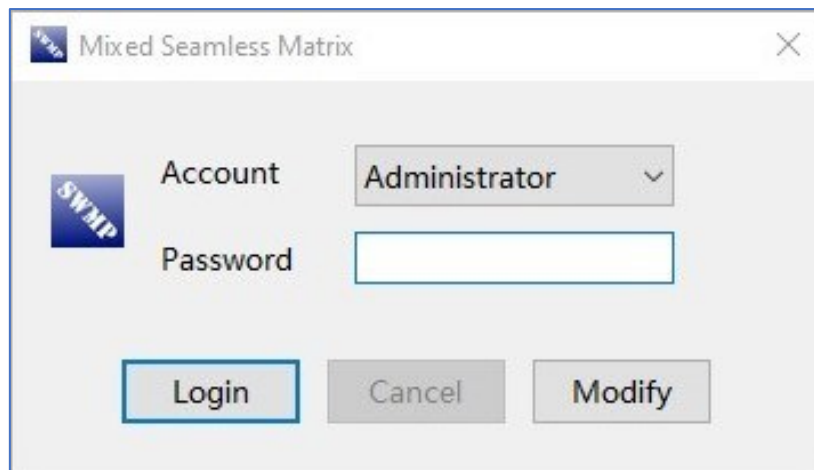

Default password for Administrator:**111111**

Default password for User: **000000**

Users can change the password here as well

1. Click drop-down list to select account: Administrator or User
2. Input current password, then click the 'modify' button to open the Modify password window

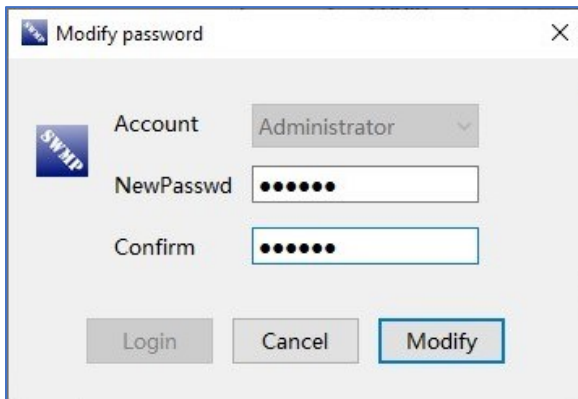

Type in new password, then click the 'modify' button to change to the new password

Once log in, the following user interface will be shown on screen. The system will remember the last connection setup and automatically try to connect the SWMP system. If not, please check **4.1.1** and **4.1.2** for how to connect the unit with control PC.

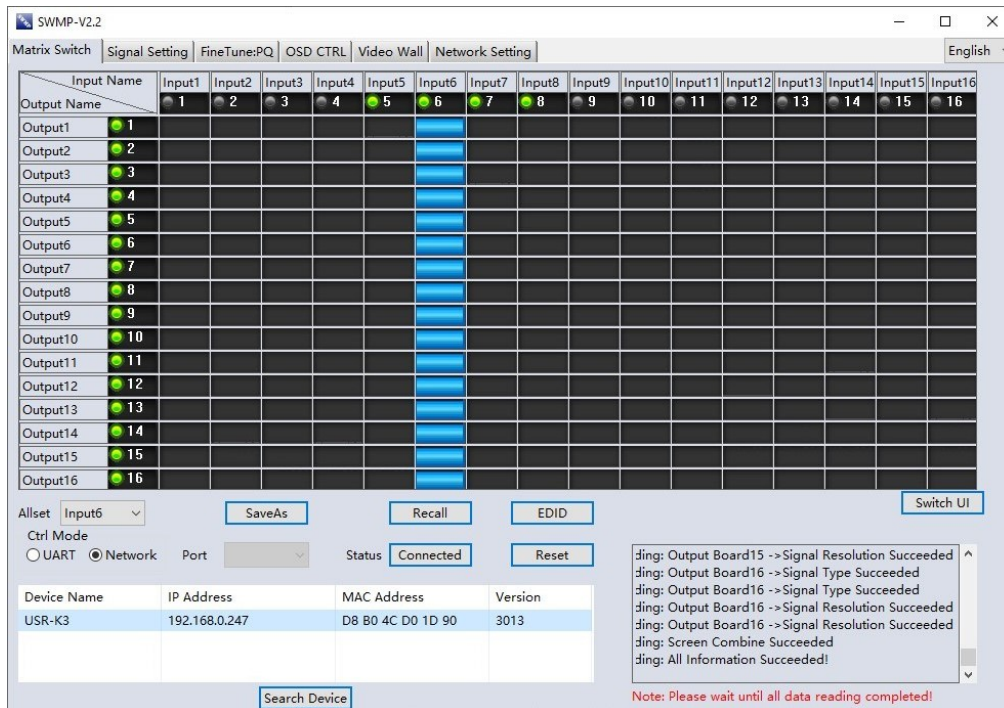

There are **6** main tabs in this software to help users set up and control the SWMP matrix switcher.

4.1. Matrix Switch

Users can connect the SWMP device to control PC and set up the device as matrix switcher in this section.

4.1.1. Connect to the SWMP via RJ45 for RS232

Connect the SWMP to the control PC with a serial cable (a RS232 to USB cable is included in the package)

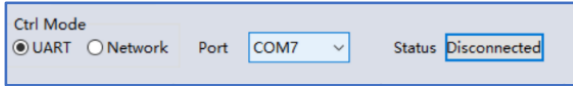

If the software was connected via UART (RS232) last time, software will connect to the SWMP automatically via RS232. If it was used at Network

last time, a 'Network Timeout' error message will be shown on screen and users need to set up as below for RS232 connection in the software

- Choose 'UART' instead of 'Network'
- Select the **COM port** from the **Port** dropdown menu
- Press 'Disconnected' button to connect

The software will check all the parts of the device. A 'Read data succeeded' dialog box will be shown on screen when finished.

4.1.2. Connect to the SWMP via Network

The default IP address for SWMP matrix switcher is **192.168.0.247**, Users need to change the IP address of the control PC to the same network segment as the SWMP.

- Change the 'Obtain an IP address automatically' to 'Use the following IP address' to set up a **static** IP address of **TCP/IPv4** in **Ethernet Properties**
 - IP address: any address between **192.168.0.2** and **192.168.0.254** except the address which has been taken by the SWMP
 - Subnet mask: **255.255.255.0**, Default Gateway: **192.168.0.1**

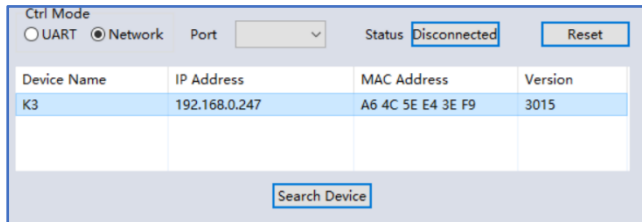

Connect the SWMP with a CAT cable to the control PC (cable included in the package)

If the software was connected via Network last time, software will connect to the SWMP automatically via network. If it was used at serial port last time, a 'Please select COM

port' error message will be shown on screen and users need to set up as below for Network connection in the software

- Choose 'Network' instead of 'UART'
- Press 'Search Device' button to find the SWMP on the network
- Highlight the device Press 'Disconnected' button to connect

4.1.3. Matrix Switch Routing

Users can switch and assign different inputs to the selected outputs in the matrix. The name of the input/output can also be changed by selecting the default name – Input1/Output1 and replacing it with the chosen name. Users need to disable the video wall mode (Cancel the splicing, see 4.5.2) to enable the matrix switcher mode.

Input Name	Input1	Input2	Input3	Input4	Input5	Input6	Input7	Input8
Output Name	1	2	3	4	5	6	7	8
Output1	1	2						
Output2	2							
Output3	3							
Output4	4							
Output5	5							
Output6	6							
Output7	7							
Output8	8							

4.1.4. Allset, Recall, Save As, Reset, EDID and Switch UI



- The **Allset** dropdown menu helps the users select a single input to be displayed on all the screens
- **Recall**: Recall a matrix switching preset layout. The device supports maximum 25 layouts.
- **SaveAs**: Save up to 25 preset layouts for matrix switching (same as video wall layouts, 4.5.3)
- **Reset**: Reset the unit to default factory configuration.
- **EDID**: Users can read the EDID from the output (from the receive device, such as screen) and

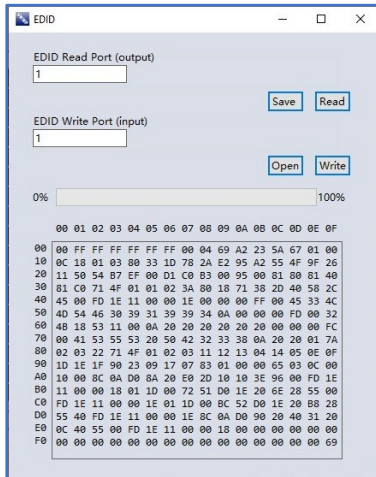

apply it to the input port

- ✓ **Read**: read the EDID of the selected output
- ✓ **Save**: save the displayed EDID after 'Read'
- ✓ **Open**: open an EDID from previous saved EDID
- ✓ **Write**: write the current displayed EDID onto selected input to customized input EDID

- **Switch UI**: users can switch UI style in this section to choose the best suitable UI for themselves.

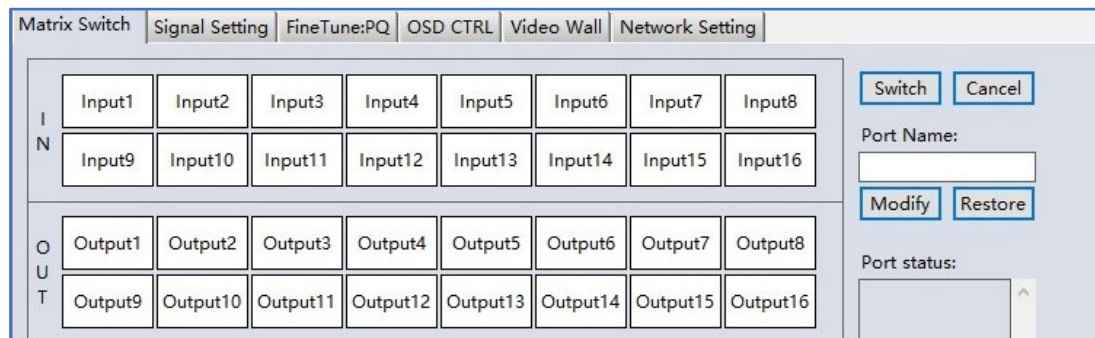
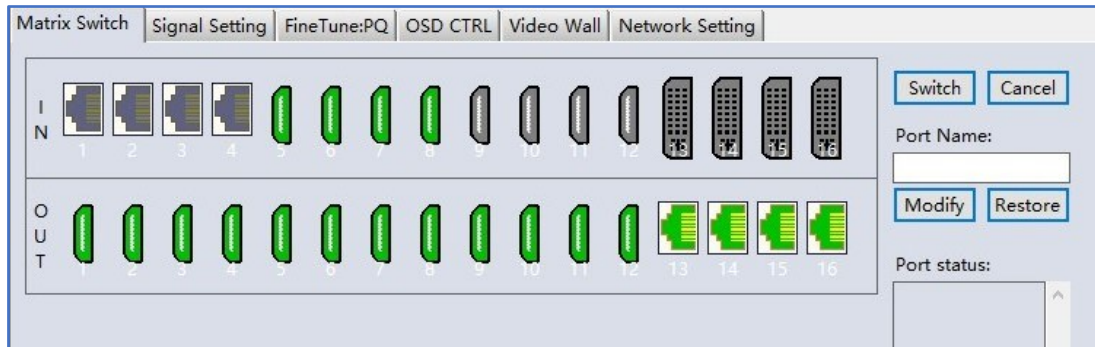

4.2. Signal setting

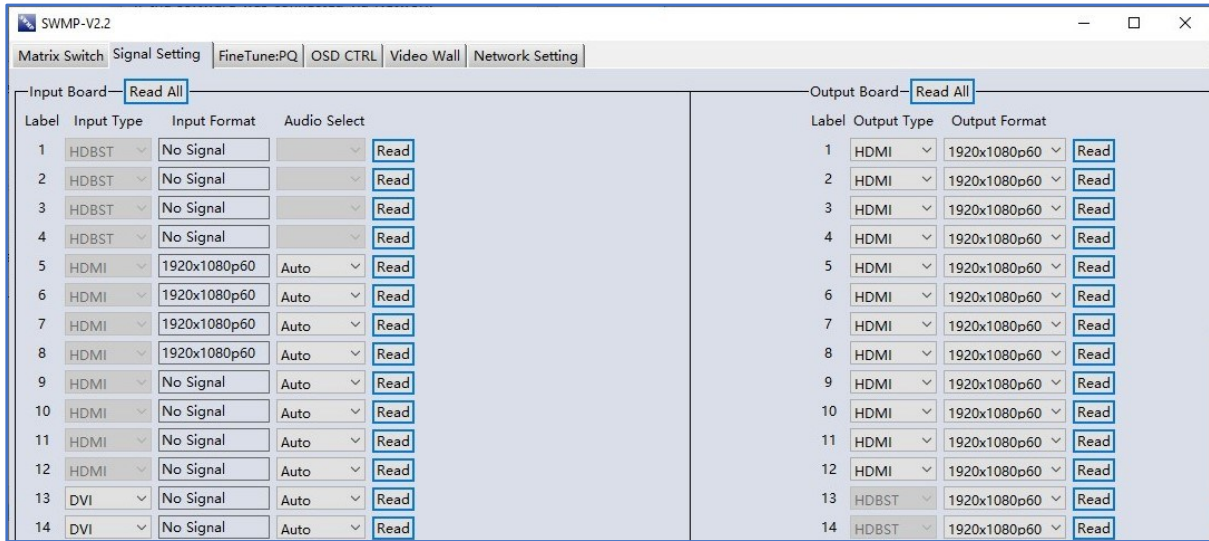

In the **Signal Settings** tab, users can use the ‘**Read All**’ function button to recognize the type and resolution automatically. Additionally, you can also manually read one Input/output at a time – pressing the **Read** button next to the selected input will only read that input alone.

- I. **Input Type** Shows the input video sources type (HDMI or DVI)
- II. **Input Format** Shows the resolution of the input video sources

III. Audio Select

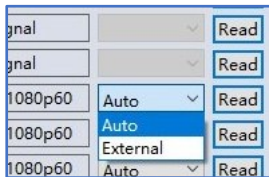

Auto: HDMI output embedded audio and analog audio output will get the audio from the embedded audio of the HDMI input to be displayed on the output channel. If the input source is DVI, the output system will get the audio from the input analog audio

External: HDMI output embedded audio and analog audio output will get the audio from the corresponding analog audio of the HDMI input to be displayed on the output channel

IV. Output Type



Users can choose different output formats for certain output cards (e.g., HDMI output card can be used as DVI or HDMI, DVI output card can be used as both digital and analog)

V. Output Format

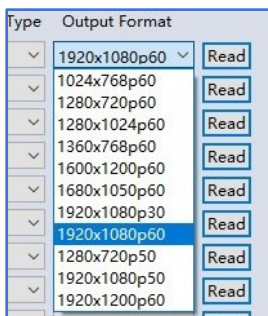

Users can manually change the output resolution here to match the requirement of the receiving side

4.3. PQ & Position

This section allows the user to fine-tune the settings of each output signal from the SWMP software.

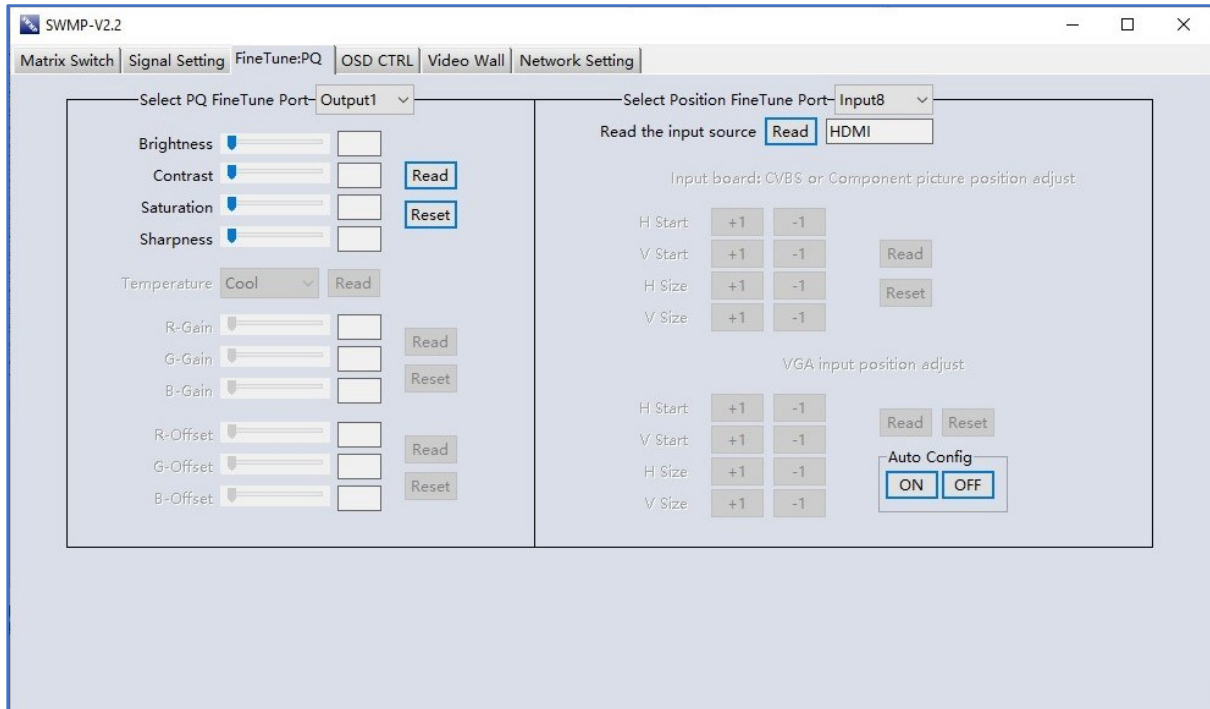

- **PQ Fine Tune**

The dropdown menu at the top of the section allows the user to select which screen to apply the settings to and Adjust the Brightness, Contrast, Saturation and Sharpness sliders to the selected output to adjust the image quality of that output.

The read option reads the settings of the monitor/screen that are already in place and adjusts the values in the software, while the reset button will reset the settings to their default after they have been manually adjusted.

- **Position Fine Tune**

This feature is only valid on CVBS, Component or VGA analog video source. Users can adjust the video source screen position in this section to match the monitor requirement.

4.4. Video Wall

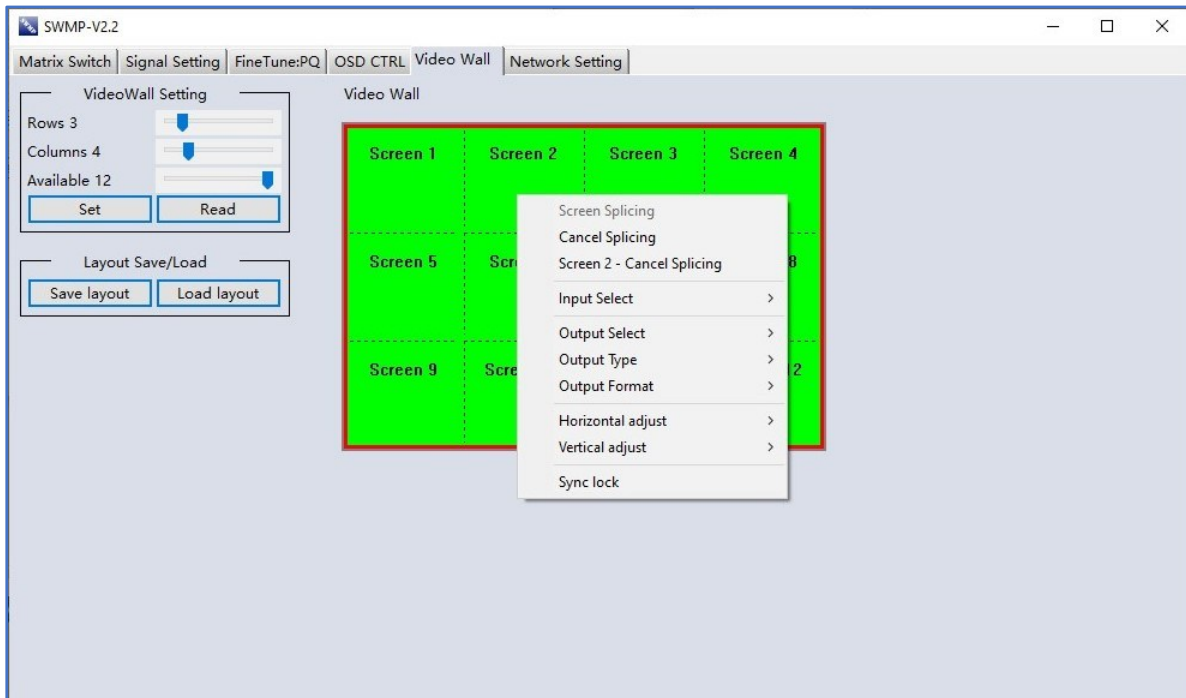

4.4.1. Video Wall Layout Setup

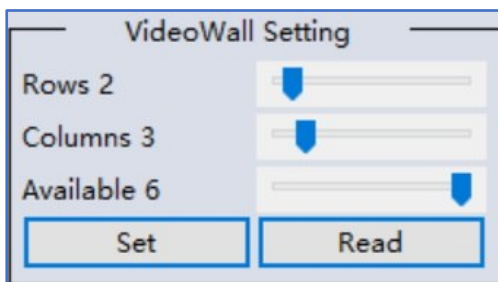

Users can set up the layout of the video wall in 'VideoWall Setting' by simply choosing how rows and columns in the video wall.

4.4.2. Creative the video wall

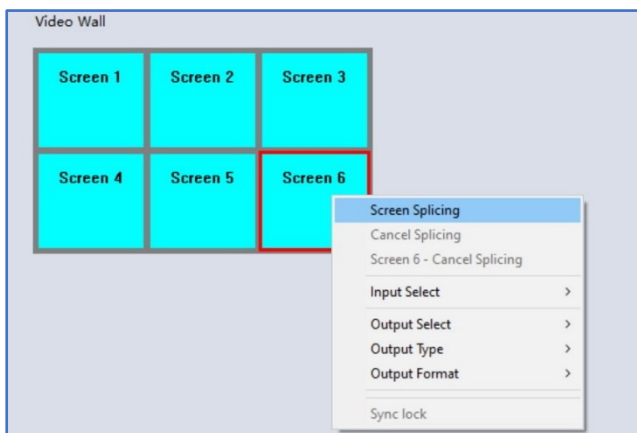

Left click to select the screen, then drag & select the screens needed to form the video wall.

Right-click, and choose 'Screen splicing' to form a video wall

Users can create more than one video wall on SWMP. (e.g., they can create two 2x2 video walls instead of one 2x4 video wall or 3, 4 independent video walls)

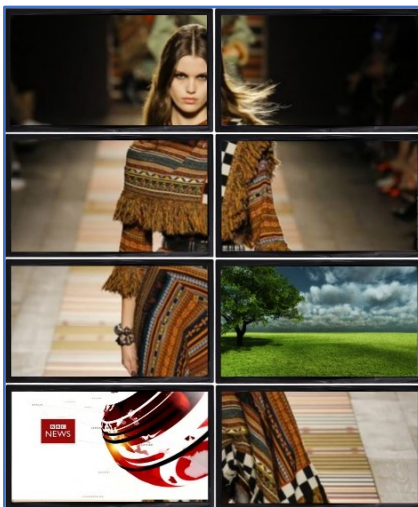

- **Screen Splicing** - This combines the selected screens into one and displays the selected input across all the splicing screens. For example, in the setup 2x4 at left, if all of them are spliced, then the input selected by the user will be displayed across all the 8 screens (**See image left**).
- **Cancel Splicing** – This will cancel the video wall and revert to the matrix switching mode
- **Screen – Cancel Splicing**– This will cancel the very screen and revert only that screen to the matrix switching mode to form a Picture in Picture effect (**See image bottom left**)
- **Input Select** –This allows the user to control which input is displayed on video wall
- **Output Select** – The user can control which screen should be mapped to which output (only available in matrix mode)
- **Output Type** – Allows the user to adjust the type of the output (only available in matrix mode)
- **Output Format** – Controls the resolution of the output (only available in matrix mode)
- **Horizontal adjust** – Bezel compensation on horizontal direction
- **Vertical adjust** – Bezel compensation on vertical direction
- **Sync lock**– to form sync between different screens in the same video wall

4.4.3. Save and Load Pre-set Layout

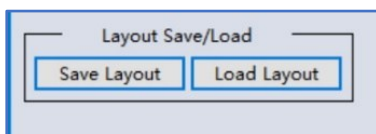

The user can save the video wall preset layouts and load it later via the **Save Layout** and **Load Layout** dropdown menu. Users can save up to 25 preset layouts here. (Same as matrix switch layouts, 4.1.4)

4.5. Network Setting

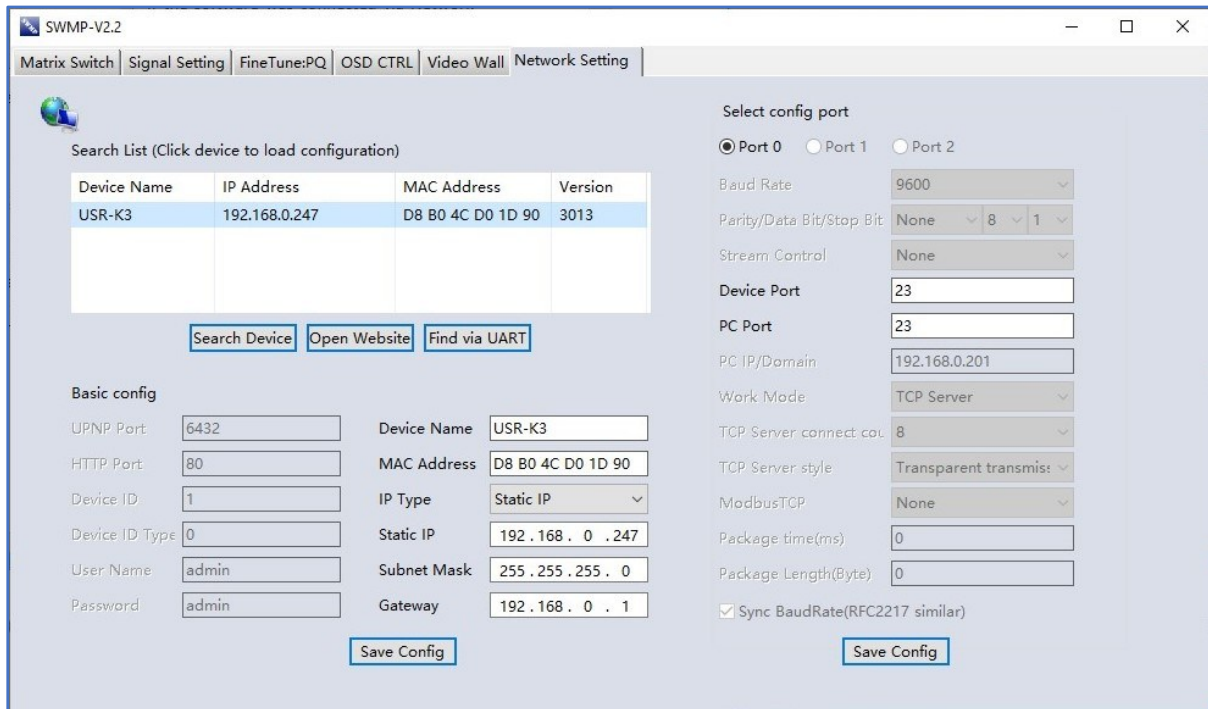

Search List (Click device to load configuration)

Device Name	IP Address	MAC Address	Version
USR-K3	192.168.0.247	D8 B0 4C D0 1D 90	3013

Buttons: Search Device, Open Website, Find via UART

Basic config

UPNP Port: 6432 Device Name: USR-K3
 HTTP Port: 80 MAC Address: D8 B0 4C D0 1D 90
 Device ID: 1 IP Type: Static IP
 Device ID Type: 0 Static IP: 192 . 168 . 0 . 247
 User Name: admin Subnet Mask: 255 . 255 . 255 . 0
 Password: admin Gateway: 192 . 168 . 0 . 1

Buttons: Save Config

Select config port

Port 0 Port 1 Port 2

Baud Rate: 9600
 Parity/Data Bit/Stop Bit: None / 8 / 1
 Stream Control: None
 Device Port: 23
 PC Port: 23
 PC IP/Domain: 192.168.0.201
 Work Mode: TCP Server
 TCP Server connect co.: 8
 TCP Server style: Transparent transmis:
 ModbusTCP: None
 Package time(ms): 0
 Package Length(Byte): 0

Sync BaudRate(RFC2217 similar)

Buttons: Save Config

Users can find all the device network information in this section and do the modification if needed. Users can find the lost IP address using 'Find via UART' which only requires RS232 connection.

5. Remote Control

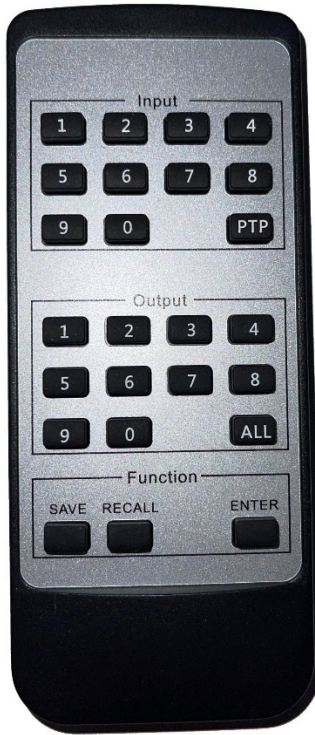

5.1. Output/Input Buttons

Press buttons **OUTPUT x + INPUT y + ENTER** in order, switch input **x** to output **y**.

- **PTP Button**

To display all the inputs to all outputs respectively

- **All Button**

Press buttons **All + Input x + ENTER** in order, to switch input **x** to all the outputs, users can use this combination to switch between different inputs to the video wall

5.2. Function Buttons

- **SAVE Button**

Press buttons **SAVE + OUTPUT y + ENTER** to save current matrix/video wall layout as layout **y** (Save up to 8 preset layouts)

- **RECALL Button**

Press buttons **RECALL + OUTPUT y + ENTER** in order, to recall layout **y** (Recall up to 8 preset layouts)

- **ENTER Button**

To enable all the actions

6. SWMP ASCII Command Lines

- Baud Rate: 9600
- Data bits: 8
- Parity: None
- Stop bits: 1
- TCP/IP port: 23

Note:

- All spaces shown in the command are required.
- All commands in this section are always terminated with the ASCII carriage-return character, 0x0d. This is represented by the ↵ symbol in each command.

6.1. Video switching

Operation type(3Byte)	Spacer (1B)	Target (3B/4B/5B)	Spacer (1B)	Command type (5B)	Command Parameters (4B/5B/6B)	Command Tail (1B)
SET	Space	INx/INxx/INxxx X: Input Number	Space	VIDEO	OUTa/OUTaa/OUTaaa or ALL	↵ This is ASCII carriage return 0x0d

For example: Switch input 1 to output 1

Send: SET IN1 VIDEO OUT1↵

Receive: IN1 VIDEO OUT1

For example: Switch input 1 to all outputs

Send: SET IN1 VIDEO ALL↵

Receive: IN1 VIDEO ALL

6.2. Save Video Wall/Matrix Preset Layout

Operation type (3B)	Spacer(1B)	Target (NB)	Spacer (1B)	Command type (10B)	Spacer (1B)	Command parameters (1/2/3B)	Command tail (1B)
SET	Space	SYS	Space	TVWALL-MODE	Space	x/xx/xxx x is the layout number	↵ This is ASCII carriage return 0x0d

For example, Save the current route to layout 1

Send: SET SYS TVWALL-MODE 1↵

Receive: SYS TVWALL-MODE 1

6.3. Load Video Wall/Matrix Preset Layout

Operation type (3B)	Spacer (1B)	Target (NB)	Spacer (1B)	Command type (10B)	Spacer (1B)	Command parameters (1/2/3B)	Command tail (1B)
GET	Space	SYS	Space	TVWALL-MODE	Space	x/xx/xxx x is the layout number	↵ This is ASCII carriage return 0x0d

For example, Load the preset layout 1

Send: GET SYS TVWALL-MODE 1↵

Receive: SYS TVWALL-MODE 1



SEADA Technology Ltd

SEADA House

Saxon Business Park

Hanbury Road

Bromsgrove, Worcestershire

B60 4AD

United Kingdom

Email: sales@seada.co.uk

Phone: +44 (0)1527 584364

Fax: +44 (0)1527 962998