

# SEADA

Showing the World

## SDC0G5-B12/B20/B30 (N) 4K PTZ Video Camera

User Manual V1.0







# COPYRIGHT INFORMATION

- Copying, reproducing or transmitting this file is not allowed if a license is not provided by our company. Unless copying this file is for the purpose of backup after purchasing this product.
- In order to keep improving the product. Our company reserves the right to make changes to product specifications without prior notice. The information in this file is subject to change without prior notice.
- To fully explain or describe how this product should be used, this manual may refer to names of other products or companies without any intention of infringement.
- Disclaimer of warranties: Our company is neither responsible for any possible technological, editorial errors or omissions, nor responsible for any incidental or related damages arising from providing this file, using, or operating this product.

# SYMBOL CONVENTIONS

The symbols that may be found in this document are defined as follows.

Symbol	Description
 <b>Explanation</b>	Provides additional information to emphasize or supplement important points of the main text.
 <b>Note</b>	Caution indicates that the user is reminded of some important operations or to prevent potential injury or property loss.
 <b>Warning</b>	Indicates a potentially hazardous situation which, if not avoided, could result in equipment damage, data loss, performance degradation, or unexpected results.
 <b>Danger</b>	Indicates a hazardous situation which, if not avoided, will or could result in death or serious injury.

# SAFETY NOTES - IMPORTANT

The following important notes must be followed carefully to run the camera and respective accessories. The camera and relative accessories are called video system in this section.

- Before installing the camera, please read this manual carefully. Please follow installation instructions indicated in this manual during installation. Please keep this manual for future use.
- The installation must be performed by qualified service installers in accordance with local rules.
- Before powering on the camera, please check the power voltage carefully. Make sure that you are using the correct power source.
- Please put the power cable, video cable and control cable in a safe place.
- Do not operate beyond the specified temperature and humidity. Working temperature range of the camera is between 0°C and +40°C. The ambient humidity range is less than 90 % RH.
- During transportation, avoid violent shaking or force the camera.
- To prevent electric shock, do not remove screws or housing of the camera. There are no self-service parts inside. Refer to qualified service personnel for servicing.
- Video cables and RS232 cables should be kept far away from other cables. Shielded and independent wiring is necessary for video and control cables.
- Never aim the lens of the camera at the sun or other extremely bright objects.
- When cleaning the camera, please use soft cloth. If the camera is very dirty, wipe it off gently with a soft cloth moistened with a weak solution of water and a neutral kitchen detergent. Wring all liquid from the cloth before wiping the camera, then wipe off all remaining dirt with a soft, dry cloth. Use lens cleaning paper to clean the lens.

Do not move the camera head manually. In doing so would result in malfunction of the camera. Do not hold the camera head when carrying the video camera.

- This camera is for indoor use only. It is not designed for outdoor use.
- Make sure the camera is not directly exposed to rain and water.
- Make sure the camera is far away from area where radiation, X-rays, strong electric waves, or magnetism is generated.

# CONTENTS

<b>1. ABOUT THE PRODUCT</b>	<b>1</b>
1.1. QUICK GUIDE	1
1.2. RTSP	1
<b>2. FEATURES</b>	<b>2</b>
2.1. CHARACTERISTICS & FUNCTIONS	2
2.2. APPLICATION SCENARIOS	2
<b>3. PRODUCT COMPONENTS</b>	<b>3</b>
3.1. LIST OF PARTS & ACCESSORIES	3
3.2. MAIN PARTS & INTERFACES	4
3.3. REMOTE CONTROL	5
<b>4. INSTALLATION</b>	<b>6</b>
4.1. SIZE AND DIMENSION	6
4.2. INSTALLATION	7
4.3. DIP SWITCHES SETTINGS	9
<b>5. WEBUI INSTRUCTION</b>	<b>10</b>
<b>6. CAMERACMS</b>	<b>16</b>
6.1. TRACKING SETTING	16
6.2. LECTURER TRACKING	16
<b>7. DEVICE MANGEMENT</b>	<b>19</b>
7.1. CAMERACMS INSTRUCTION	19
7.2. REMOTE CONFIGURATION	21
<b>8. MENU SETTINGS</b>	<b>29</b>
8.1. MENU CONFIGURATION	29
8.2. MENU EXPLANATION	33
<b>9. TECHNICAL SPECIFICATIONS</b>	<b>36</b>
<b>10. TROUBLESHOOTING</b>	<b>38</b>

# 1. ABOUT THE PRODUCT

## 1.1 Quick Guide

The camera can be accessed and controlled via the following ways:

- WebUI: Camera control, network setting.
- Camera CMS: camera search and control, network setting.
- VLC: watch the camera two streams.
- ONVIF: version 2.1 supported                      Name: admin  
Initial password: leave empty
- Network pass-through: recommended connection mode with recording or streaming device.

## 1.2 RTSP

- 1) Make sure PC and the camera are in the same LAN.
- 2) Two channel streams, URL: `rtsp://IP Address:554/chx, x=1, 2`. 1 is the main stream, 2 is the sub stream. e.g. `rtsp://192.168.5.163:554/ch1`
- 3) Default RTSP port is 554.

## 2. FEATURES

### 2.1 Characteristics & Functions

- 1/2.8"4K CMOS, 8.46MP.
- 4K ultra-HD lens, 12x optical zoom, up to 81° FOV.
- Built in the industry-leading AI image algorithm for human body detection and locking tracking, which can realize a wide range of automatic detection and continuous tracking.
- H.264/H.265 video compression, up to 4K60 video output, and support POE.
- HDMI 2.0 video output, up to 4K60 video output.
- USB 2.0 with UVC and UAC protocols, up to support 4K60 video output.
- 3G-SDI video output.
- Support RS232 IN/ RS232 OUT control interface and VISCA protocol.
- 1 channel LINE IN.
- Fast, accurate and smooth focusing.
- High precision, smooth rotation, quiet PTZ.

### 2.2 Application Scenarios

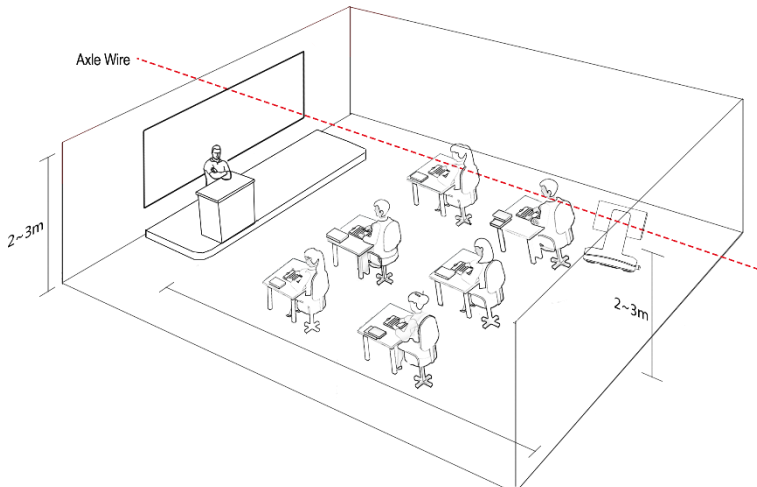

# 3. PRODUCT COMPONENTS

## 3.1 List Of Parts & Accessories

When you open the box, check all accessories according to the packing list.

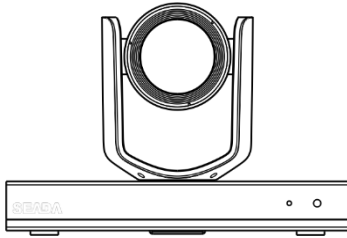

**Camera x 1**

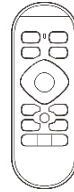

**Remote Controller x 1**

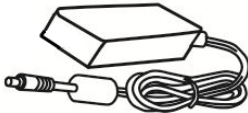

**Power Adapter x 1**



**RS-232 Cable x 1**

## 3.2 Main Parts & Interfaces

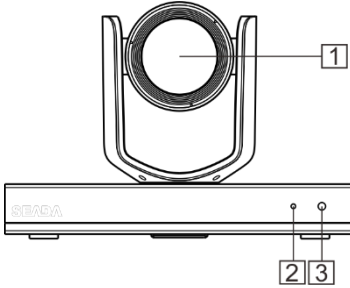

Front View

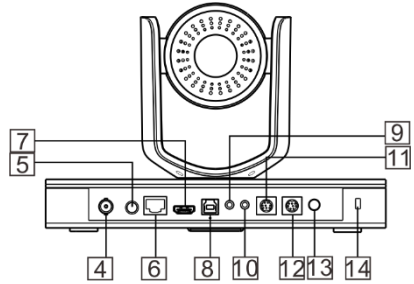

Rear View

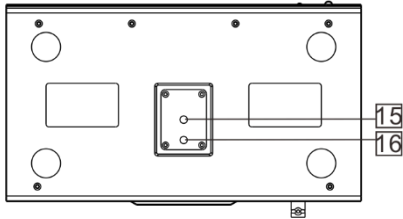

Bottom View

NO.	Interface	NO.	Interface
1	Camera Module	9	REF
2	Status Indicator	10	LINE IN
3	IR Receiver	11	RS232-IN
4	3G-SDI	12	RS232-OUT
5	SW	13	DC12V
6	LAN	14	Kensington Security Slot
7	HDMI	15	Mounting Hole, 1/4"-20UNC
8	USB	16	Locating Hole, $\Phi$ 5mm

### 3.3 Remote Control

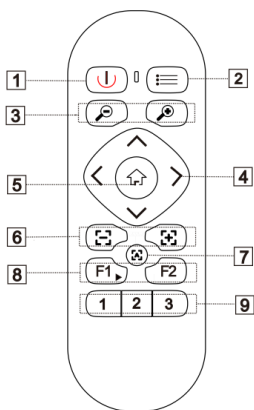

No.	Name	Function
1	Power	After the camera has been connected to power source, press the button, camera will be standby or running.
2	Menu	Open/close the OSD menu.
3	Zoom	⊕ zoom in, ⊖ zoom out.
4	Direction	In menu mode, set menu options; In non-menu mode,   used for vertical adjustment of the screen.
5	Home	 In menu mode, confirm to enter. In non-menu mode, the screen returns to the original position.
6	Focus	- focus near,  - focus far.
7	Autofocus	- auto adjust the camera focus.
8	F1/F2	F1: After pressing the button for 5 seconds, press the digital button to set the IR address. Or press for a short time to turn on tracking. F2: Press for a short time to turn off tracking.
9	Number	Press for three seconds to set the preset, and press for a short time to call the preset.

# 4. INSTALLATION

## 4.1 Size And Dimension

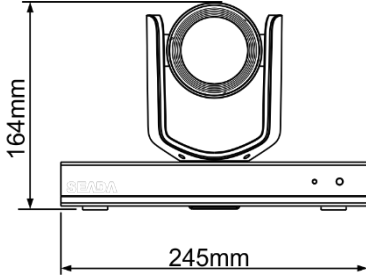

Front

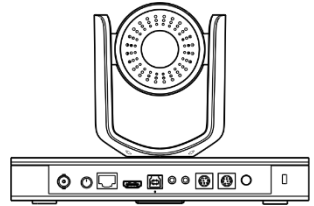

Rear

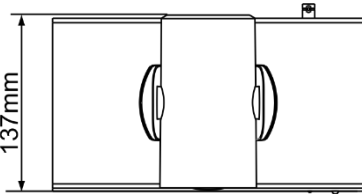

Top

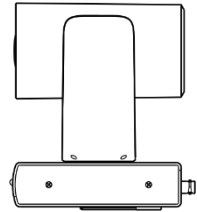

Side

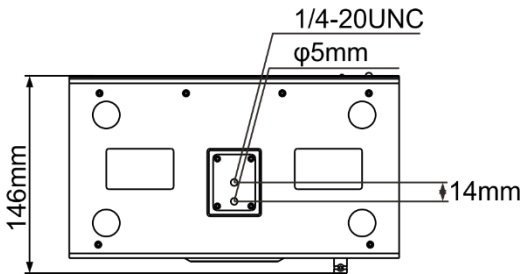

Bottom

## 4.2 Installation

Ceiling or wall mounting brackets can only be mounted on template and concrete wall. For safety reasons, plasterboard is not recommended.

### 4.2.1 Wall Mount

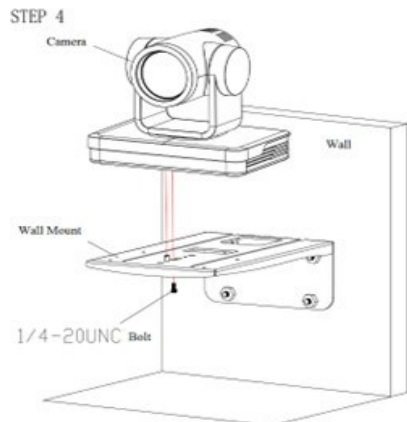
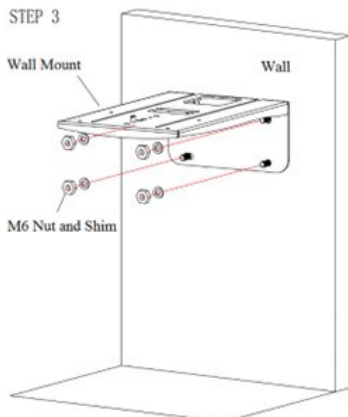
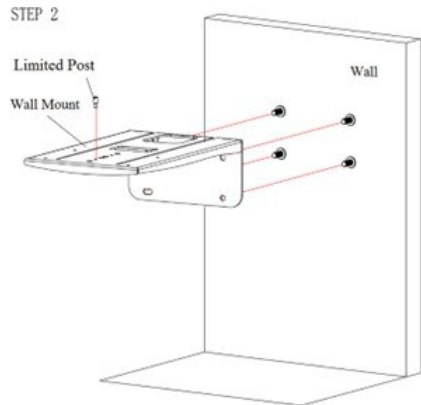
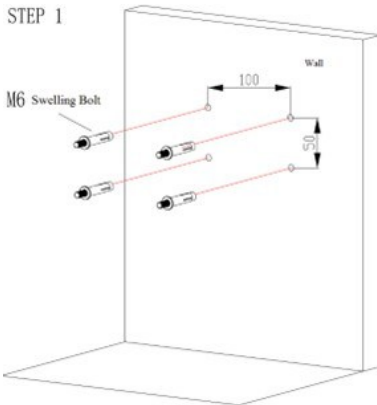

## 4.2.2 Ceiling Mount

STEP 1

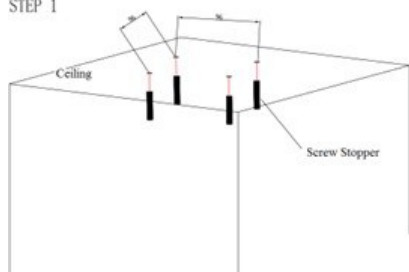

STEP 2

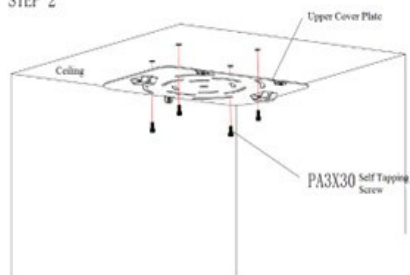

STEP 3

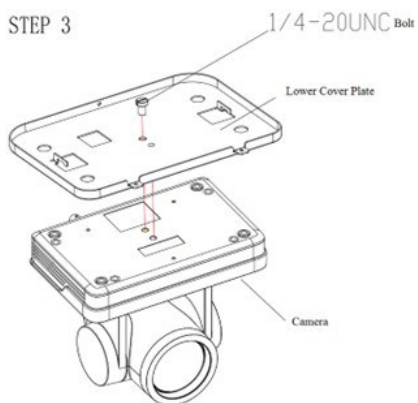

STEP 4

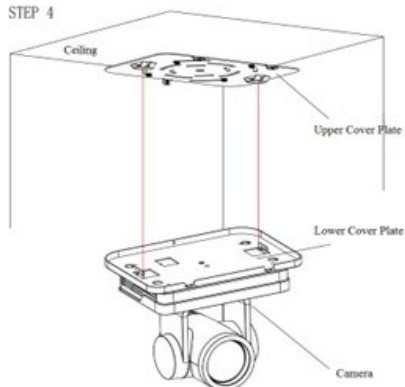

STEP 5

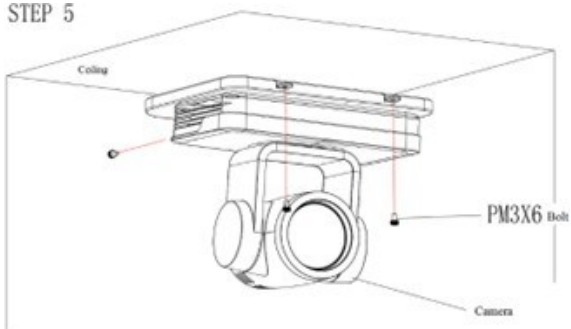

### 4.3 DIP Switches Settings

Before installing and operating the camera, set the camera video output format through DIP switches, The camera has 16-digit DIP switches, as below:



No. 0~9 are used to set different video formats; No.A~E are reserved for future use; No. F is used to set video format custom.

SW			
0	1080P60	8	4K50
1	1080P50	9	4K60
2	720P60	A	— —
3	720P50	B	— —
4	1080P30	C	— —
5	1080P25	D	— —
6	4K25	E	— —
7	4K30	F	Custom

#### Note

Please reboot the camera after adjusted the settings.

# 5. WebUI Instruction

## 5.1 Web Client

To Access the Web Client Interface, type the device's IP address (default = 192.168.5.163) in the address field of your internet browser and press enter to access the Web Client login page. You can log in as a standard user or as an administrator.

When logging in as an administrator (**Default Username:**

**admin**; **Password: admin**), administrators can preview the

camera image and configure the camera settings; If logging in

as a '**standard operator**', users cannot access the option for the firmware upgrade; If logging in

as a '**standard user**', users can only preview image from the camera.

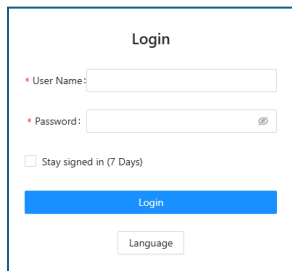

## 5.2 Live View

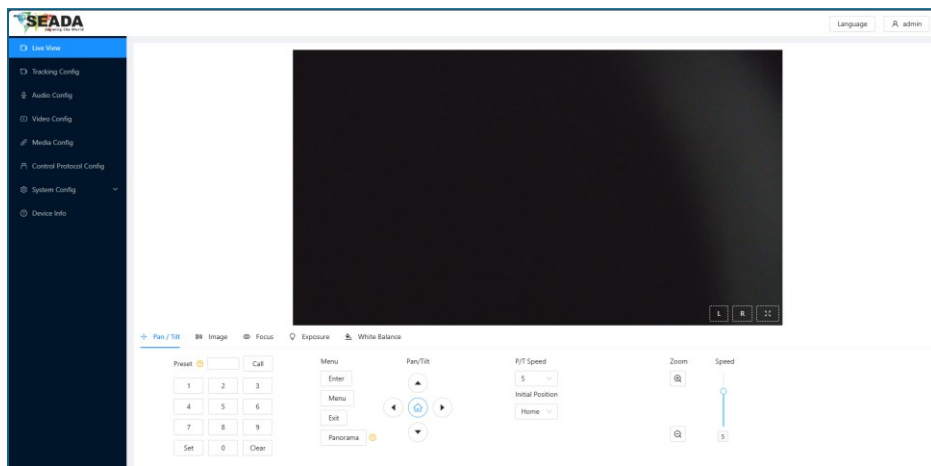

After successful login into the management interface, it enters the video preview interface. In the preview screen, users can control PTZ, zoom, focus, full screen, rotate, change image parameter, call menu and set the preset position and recall, and other operations.

## 5.3 Tracking Config

Users can Control PTZ and enable/disable tracking of the camera. Enable and change of tracking height will confirm the activated zone for the camera to track.

Users can also change the sensitivity, speed and target lost

time of the tracking and decide whether the camera tilts during tracking.

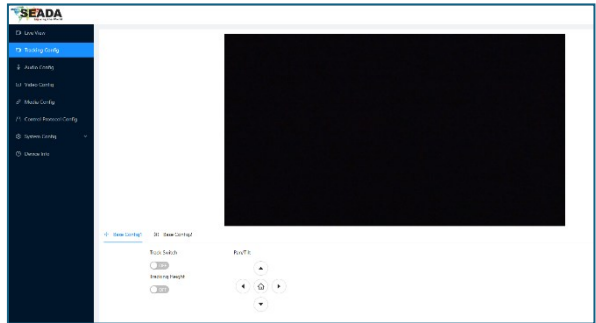

## 5.4 Audio Config

**Audio Input:** Line-in only.

**Sample Rate:** Sampling frequency. (48KHz)

**Input Volume:** Set the input audio volume.

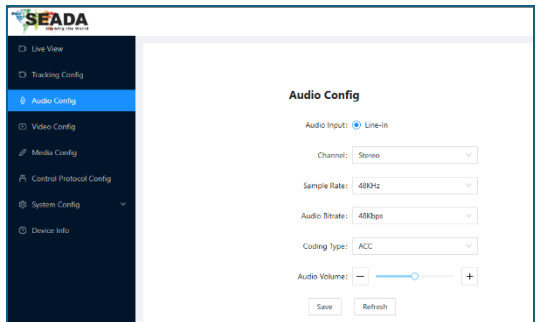

## 5.5 Video Config

**Video Output Config**

Stream Type: Main Stream

Resolution: 1080P

Bitrate Type: Constants Bit Rate

Bitrate Kbps: 4000

Video Frame Rate: 30

Encoding Type: H264

Encoding Level: High

I-Frame Interval: 30

Save Refresh

**Video Format Config**

Video Format: 1080P60

Save Refresh

**Stream Type:** Different video output mode setting, use different streams. (Main stream, Sub stream)

**Resolution:** Set video image resolution. (Mainstream default 1920\*1080, 640\*360, 1280\*720 and 3840\*2160 as option; Sub stream default 1280\*720, 640\*320, 1920\*1080 as option)

**Bitrate Type:** Set rate control mode. (Main/Sub stream default constants bit rate, variable bit rate as option).

**Bitrate Kbps:** Set the video bit rate. (Main/Sub stream default 4000Kb/s, 2000 - 12000Kb/s as option)

**Video Format Rate:** Set the video frame rate. (Main/sub stream default 30 Frame/s, 1-60 Frame/s as option)

**Encoding Type:** Set the video compression format. (Main/Sub stream default: H.264, H.265 as option)

**Encoding Level:** Set the image quality. (Main/Sub stream default: High, Base/Main as option)

**I-Frame interval:** Set the key frame interval. (Main/Sub stream default 30, Main/Sub 1 – 255 as option.)

**Video Format:** Set the HDMI output resolution. (Default 4K60, 720P50/60, 1080P25/30/50/60, and 4K25/30/50/60.)

## 5.6 Media Config

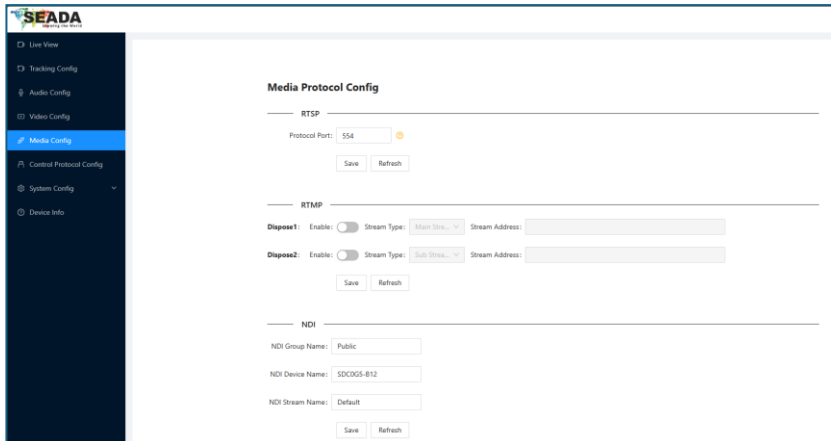

The screenshot shows the SEADA Media Protocol Config interface. On the left is a dark blue sidebar with navigation options: Live View, Tracking Config, Audio Config, Video Config, Media Config (highlighted), Control Protocol Config, System Config, and Device Info. The main content area is titled 'Media Protocol Config' and is divided into three sections: RTSP, RTMP, and NDI. The RTSP section has a 'Protocol Port' field set to 554 and 'Save' and 'Refresh' buttons. The RTMP section has two 'Dispose' entries, each with an 'Enable' toggle (disabled), a 'Stream Type' dropdown (set to 'Main Stream' and 'Sub Stream' respectively), and a 'Stream Address' field, with 'Save' and 'Refresh' buttons at the bottom. The NDI section has three text input fields: 'NDI Group Name' (set to 'Public'), 'NDI Device Name' (set to 'SDCCGS-B12'), and 'NDI Stream Name' (set to 'Default'), with 'Save' and 'Refresh' buttons at the bottom.

**Protocol Port:** Change the port for the RTSP protocol. (Default 554)

**RTMP:** Set RTMP stream for camera.

**NDI:** Set NDI parameters for the camera, including NDI Group Name, NDI Device Name and NDI Stream Name.

## 5.7 Control Protocol Config

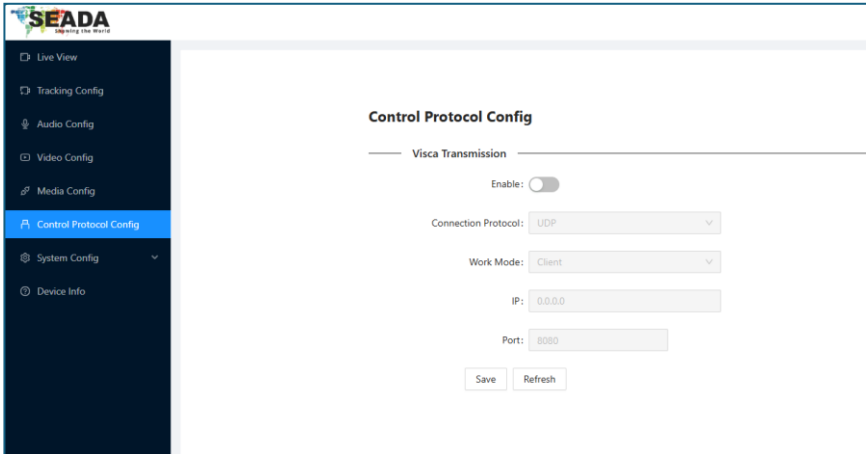

**SEADA**  
Smoothing the world

Live View  
Tracking Config  
Audio Config  
Video Config  
Media Config  
**Control Protocol Config**  
System Config  
Device Info

### Control Protocol Config

Visca Transmission

Enable:

Connection Protocol: UDP

Work Mode: Client

IP: 0.0.0.0

Port: 8080

Save Refresh

**Enable/Disable:** Enable/Disable transparent transmission.

**Connection Protocol:** Choose TCP/UDP protocol.

**Work Mode:** Choose Client or Server.

**IP:** When the camera is set as client, the IP address of the transmitted camera is needed. When the camera is set as server, the IP address can be left as blank.

**Port:** Choose from 1-65535 as transparent transmission port.

## 5.8 System Config

### 5.8.1 User Manage

**User Role:**

Admin – Access to all functions.

Operator – Access to all functions except firmware upgrade.

User – Access to preview only.

## 5.8.2 Ethernet Config

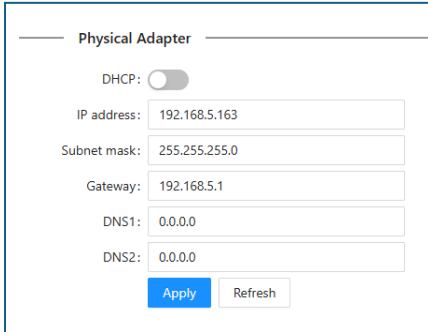

Physical Adapter

DHCP:

IP address: 192.168.5.163

Subnet mask: 255.255.255.0

Gateway: 192.168.5.1

DNS1: 0.0.0.0

DNS2: 0.0.0.0

Apply Refresh

**DHCP:** Enable or disable obtain IP automatically can be set.

**IP Address:** Set the IP address. (Default 192.168.5.163). Note: This IP address is the same as the one used to login to the Web page.

**Subnet Mask:** Set the subnet mask. (Default 255.255.255.0)

**Default Gateway:** Set the default gateway. (Default 192.168.5.1)

**DNS1/DNS2:** Set the server prior. (Default 0.0.0.0)

## 5.8.3 Firmware Update

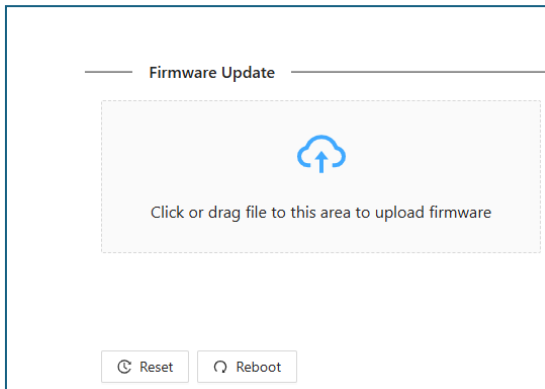

Firmware Update

Click or drag file to this area to upload firmware

Reset Reboot

**Firmware Update:** upgrade to new firmware

**Reset:** Factory reset the camera.

**Reboot:** Reboot the camera.

## 5.9 Device Info

**Device Type:** Device name.

**Firmware Version:** Device firmware version.

**Device MAC Address:** Device MAC Address.

## 6. CameraCMS

### 6.1 Software Connection

Install "CameraCMS" on your PC, open "CameraCMS", connect and add camera to the management device list, and enter the user interface. Select one of a camera to do the following settings:

#### 6.1.1 Tracking Settings



**Start:** Turn on tracking. Using a controller or software to recall preset 80 can also turn on tracking.

**Stop:** Turn off tracking. Using a controller or software to recall preset 81 can also turn off tracking.

**Settings:** Click this button to get into advanced tracking parameters for configuration.

### 6.2 Lecturer Tracking

#### 6.2.1 Setting Process

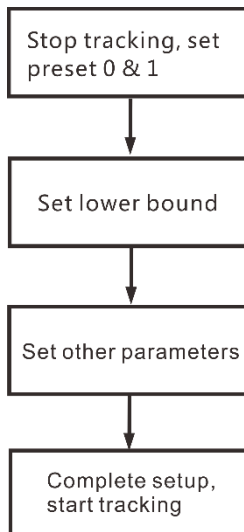

**Preset 0:** It is a position that can be configured to have the camera move to once tracked object gets lost, recommended to set at a full view image of the lecturing area. See basic parameter settings for details.

**Preset 1:** Preset 1 is the position where tracking starts, preferred to be set at Podium; to configure it, move the camera's Pan/Tilt/Zoom to put the lecturer in the appropriate size and position in the image, then set it as preset 1. In some other cases, preset 1 is also useful: after camera finishes calibration, it will sit at preset 1; once tracking object gets lost, the camera can be configured to move to preset 1; when the camera starts auto zooming, its zooming times is also based on preset 1's zooming times.

## 6.2.2 Tracking Setting

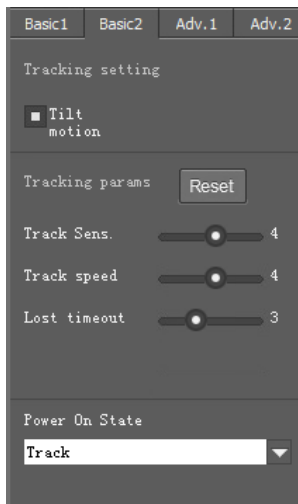
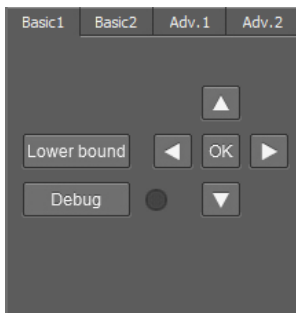

## 6.2.3 Basic Parameters Setting

### 6.2.3.1 Basic 1

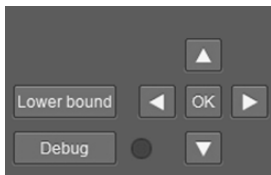

**Lower Bound:** It is used to adjust the lower boundary of the lowest detecting position.

**Debug:** Enable and disable display current status of body detection of tracking camera.

### 6.2.3.2 Tracking Setting

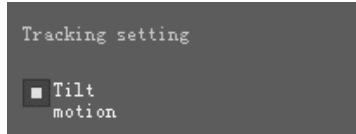

**Tilt Motion:** When it's enabled, the camera will automatically adjust tilt angle during tracking. When it's disabled, the camera will track as per the tilt angle of preset 1.

If the lecturer does not walk into the student area, it's suggested to disable auto zoom and tilt motion.

### 6.2.3.3 Tracking Parameters



**Track Sens:** Set sensitivity of tracking based on speed of movement. High sensitivity will track at small movement.

**Track Speed:** Set pan speed for tracking.

**Lost Timeout:** Set the interval before Object Lost Action will be performed, (go to preset 1 or 0). Default is 5 seconds.

### 6.2.3.4 Power On State



**Power On State:** Default status is tracking or non-tracking when powering on the camera.

# 7. DEVICE MANAGEMENT

## 7.1 CameraCMS Instruction

Install and open CameraCMS on PC, enter the user interface:

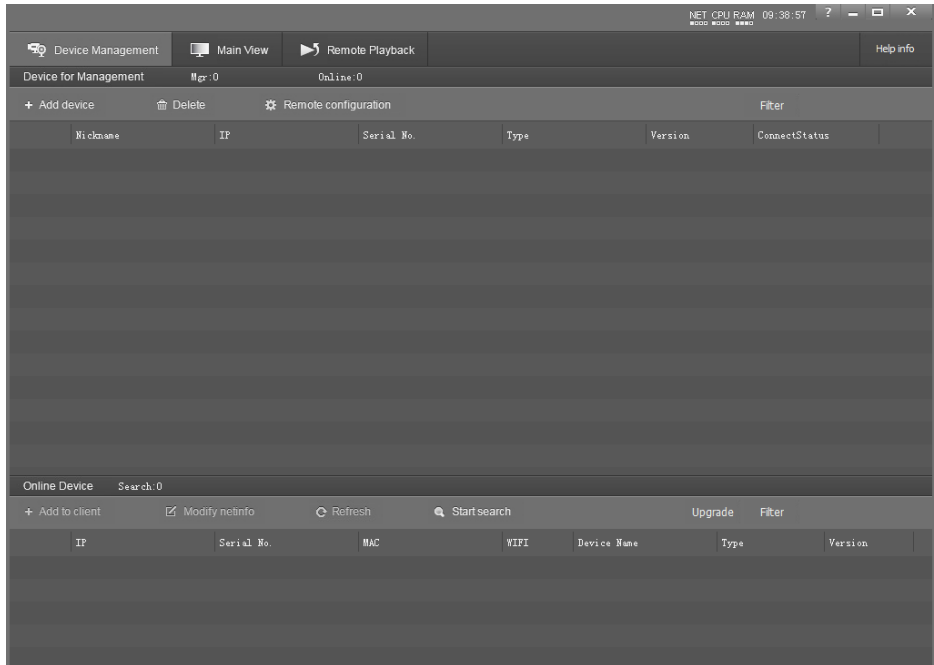

If the camera and PC are in the same LAN, click **Start Search**, then search starts and all online devices will be listed, as the picture shown below:

Online Device		Search: 14					
+ Add to client		<input checked="" type="checkbox"/> Modify netinfo	<input type="checkbox"/> Refresh	<input type="checkbox"/> Stop search	Upgrade		Filter
	IP	Serial No.	MAC	WIFI	Device Name	Type	Version
001	10.0.3.177	32K020823F06QV86K3J4	00:04:05:08:FE:D9	No	Camera 1	Camera 1	5.1.54
002	10.0.3.106	I4V672H2BD0TQV10R080	00:04:05:01:88:69	No	Camera 2	Camera 2	2.2.02
003	10.0.3.196	V523B502UDOSQU70L4R4	00:04:05:0F:6F:35	No	Camera 3	Camera 3	2.2.02
004	10.222.2.21	70C382H22B0IQV55F056	00:04:05:02:0F:88	No	Camera 4	Camera 4	2.2.01
005	10.0.3.191	N12337P2W10UQVJ1J5H5	00:04:05:07:A4:D1	No	Camera 5	Camera 5	2.1.29

To modify the device's network information, enter the IP address, mask, gateway in the **Modify Network** column.

✕

**Modify Network Parameter**

Ethernet

Device information:

CameraName:

Mac:

SN:

Network information:

ConnType:

IP:

Mask:

GateWay:

DNS1:

DNS2:

To control and preview a camera, first choose the device, modify its IP address as the IP address of the same LAN, then click **Add To Client** as the picture shown below.

Online Device		Search: 14					
+ Add to client		<input checked="" type="checkbox"/> Modify netinfo	<input type="checkbox"/> Refresh	<input type="checkbox"/> Stop search	Upgrade		Filter
IP	Serial No.	MAC	WIFI	Device Name	Type	Version	
001	10.0.3.177	32R020R2SP06QUN6K3J4	00:04:05:08:FE:19	No	Camera 1	Camera 1	5.1.54
002	10.0.3.106	I4V672H2BDOTQU10K080	00:04:05:01:88:69	No	Camera 2	Camera 2	2.2.02
003	10.0.3.196	V5238502UD0SQU70L4R4	00:04:05:0F:6F:35	No	Camera 3	Camera 3	2.2.02
004	10.222.2.21	70C382H22B01QU35F055	00:04:05:02:0F:88	No	Camera 4	Camera 4	2.2.01
005	10.0.3.191	X12337P2W10UQUJ1J5U5	00:04:05:07:A4:D1	No	Camera 5	Camera 5	2.1.29

Please check that all IP addresses are in the same LAN.

## 7.2 Remote Configuration

Choose the camera in the device list, click [Remote Configuration](#) to upgrade or config the camera.

### 7.2.1 Streaming

The screenshot shows a 'Remote Configuration' dialog box with a 'Streaming' tab selected. The dialog has a title bar with a close button (X) and a tabbed interface with options: Streaming, Network, Rtmp, Protocol, Upgrade, UN/PW, and UP.PM. The 'Streaming' tab contains the following settings:

Stream type	Main stream	Channels	STEREO
Resolution	1080P	Encode type	AAC
Video rate type	CBR	Sample rate	48KHz
Max rate(Kbps)	4000	Audio rate	48Kbps
Frame rate	30	Input pin	LineIn
Key frame interval	30	Volume	50
Video coding type	H264		
Encode Level	High		

There are two 'Save' buttons: one at the bottom left and one at the bottom right.

- **Stream Type:** Set the parameters of main stream, sub stream.
- **Resolution:** Set among 4K (3840\*2160), 1080P (1920\*1080), 720P (1280\*720), 360P (640\*360), choose resolutions based on actual requirements and capability of device. The higher the resolution is, the better network requirements will be needed.
- **Video Rate type:** Choose CBR or VBR.
- **Max Rate:** Configure max stream rate or adjustable stream rate.
- **Frame Rate:** Choose from different frames per second.
- **Key Frame interval:** Configure the number of frames between the two key frames. The larger the key frame interval is, the smaller the fluctuation of the byte will be, but the image quality is

relatively poor. Vice versa, the larger the fluctuation of the byte will be, the higher the image quality will be.

- **Video Coding type:** Choose H.264 or H.265.
- **Encode Level:** Choose from Base, Main and High.
- **Channels:** STEREO.
- **Encode Type:** AAC.
- **Sample Rate:** 48KHz.
- **Audio Rate:** Choose from 48Kbps, 64Kbps, 96Kbps and 128Kbps.
- **Input Pin:** LinIn.
- **Volume:** The range of volume is 0~100.

## 7.2.2 Network

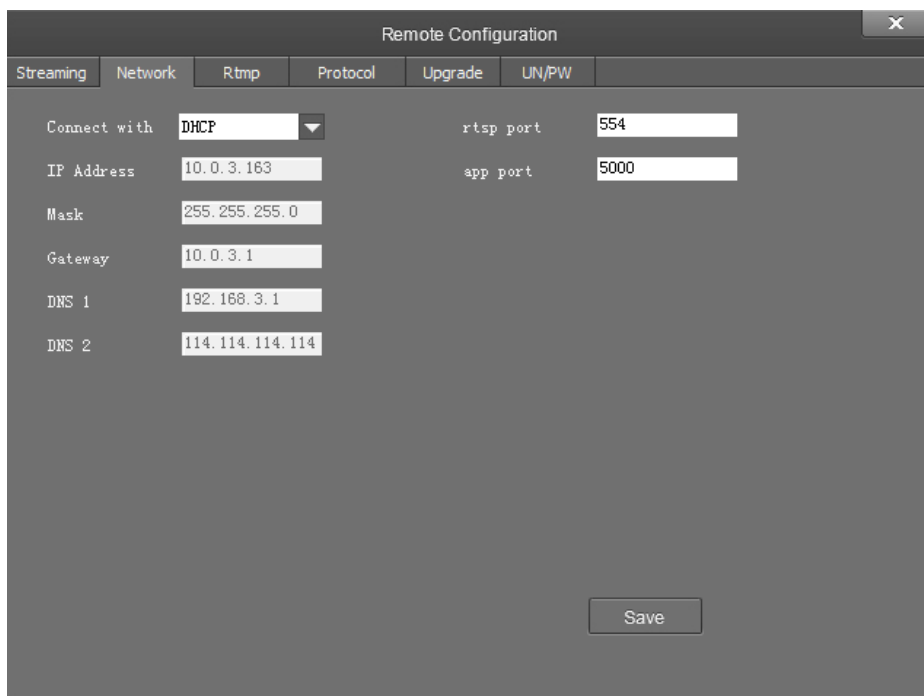

The screenshot shows a 'Remote Configuration' dialog box with a 'Network' tab selected. The dialog has a title bar with a close button (X) and a tabbed interface with options: Streaming, Network, Rtmp, Protocol, Upgrade, and UN/PW. The Network tab contains the following fields:

Connect with	DHCP	rtsp port	554
IP Address	10.0.3.163	app port	5000
Mask	255.255.255.0		
Gateway	10.0.3.1		
DNS 1	192.168.3.1		
DNS 2	114.114.114.114		

A 'Save' button is located at the bottom right of the dialog.

- **Connect With:** Choose from Static IP or DHCP address.

- **IP Address:** IP address for the camera.
- **Mask:** Mask address for the camera.
- **Gateway:** Gateway IP address.
- **DNS 1:** Server-prior, DNS address for the device.
- **DNS 2:** It will be used in case the DNS1 server is not working.
- **Port:** Streaming port (RTSP) and application port (SDK connection) can be configured. The range of stream ports is 3479~7999 and 554, default is 554. The range of application ports is 3479~7999, default is 5000.
- Click the **Save** button after setting is completed.
- Camera will connect to ethernet after above-mentioned operations.

### 7.2.3 RTMP

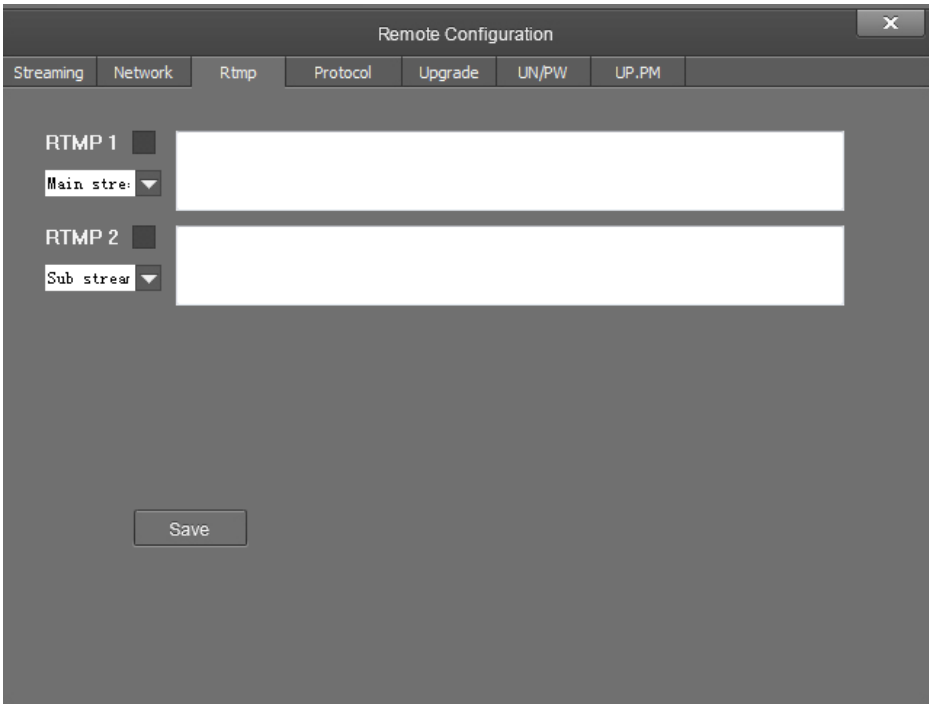

In RTMP1 and RTMP2, main stream, sub stream can be chosen to stream.

## 7.2.4 Protocol

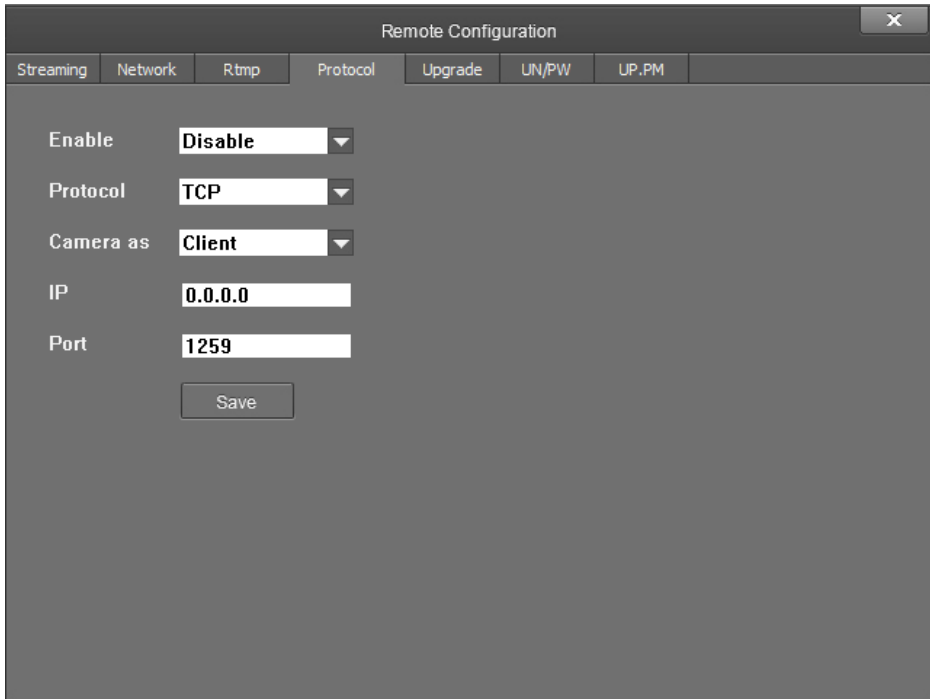

The image shows a screenshot of a software interface titled "Remote Configuration". At the top, there is a navigation bar with several tabs: "Streaming", "Network", "Rtmp", "Protocol", "Upgrade", "UN/PW", and "UP.PM". The "Protocol" tab is currently selected. Below the navigation bar, the configuration area contains several settings:

- Enable:** A dropdown menu set to "Disable".
- Protocol:** A dropdown menu set to "TCP".
- Camera as:** A dropdown menu set to "Client".
- IP:** A text input field containing "0.0.0.0".
- Port:** A text input field containing "1259".

At the bottom of the configuration area, there is a "Save" button.

- **Enable / Disable:** Enable / Disable transparent transmission.
- **Protocol:** Choose TCP or UDP protocols.
- **Camera As:** Choose Client or Server.
- **IP:** When the camera is set as client, the IP address of the transmitted camera is needed. When the camera is set as server, the IP address can be left as black.
- **Port:** Choose from 1-65535 as transparent transmission port.

## 7.2.5 Upgrade

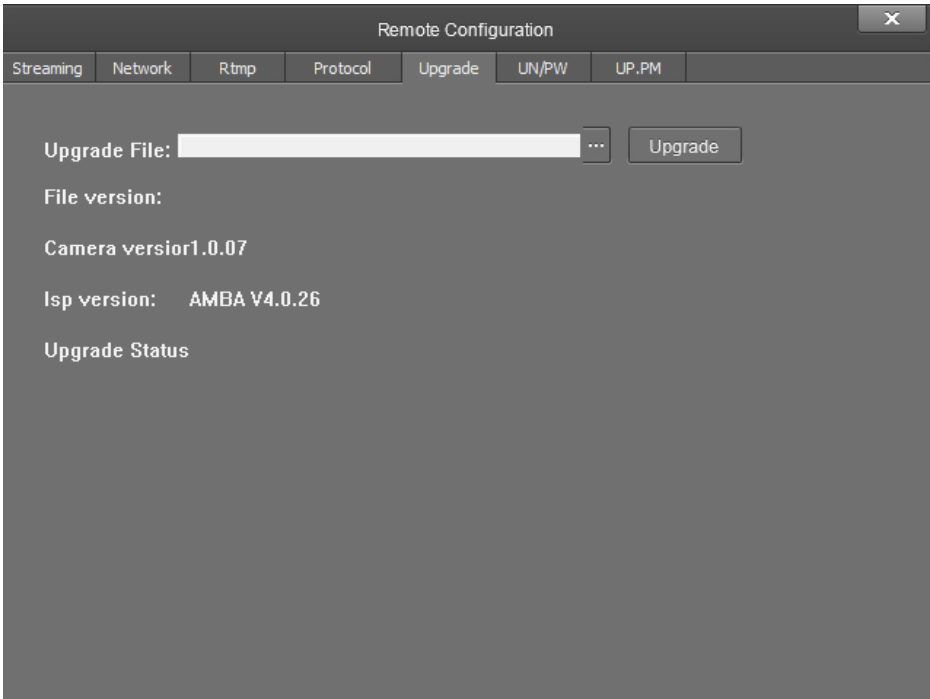

Click **Upgrade** menu to enter the main interface, as the picture shown above.

Click **...** to search and load the updating firmware, then click **Upgrade** to start upgrading. Do not power off the camera during upgrading. After the upgrading is completed, the camera will reboot.

## 7.2.6 UP/PW

The screenshot shows a 'Remote Configuration' window with a tabbed interface. The 'UP/PW' tab is selected. The window contains the following fields and controls:

- Old password:** A text input field.
- New password:** A text input field.
- Confirm:** A text input field.
- Save:** A button located below the password fields.
- Camera name:** A text input field containing the text 'Camera1'.
- Save:** A button located below the camera name field.
- Local Time:** A text field showing '2021-11-30 16:57:4' with an 'OK' button to its right.
- Display Time:** A checkbox that is currently checked.
- Time Format:** A dropdown menu showing 'YYYY-MM-DD HH:mm:ss' with an 'OK' button to its right.
- Enable NTP:** A dropdown menu showing 'Disable' with an 'OK' button to its right.
- TimeZone:** A dropdown menu showing '+00:00' with an 'OK' button to its right.
- NTP Server:** A text input field with an 'OK' button to its right.
- Reboot:** A label with two buttons: 'Reboot' and 'Reset'.

- **Password setting:** When a password is required, the camera can be accessed only after a correct password is entered.
- **Reboot:** Reboot the camera.

## 7.2.7 UP.PM

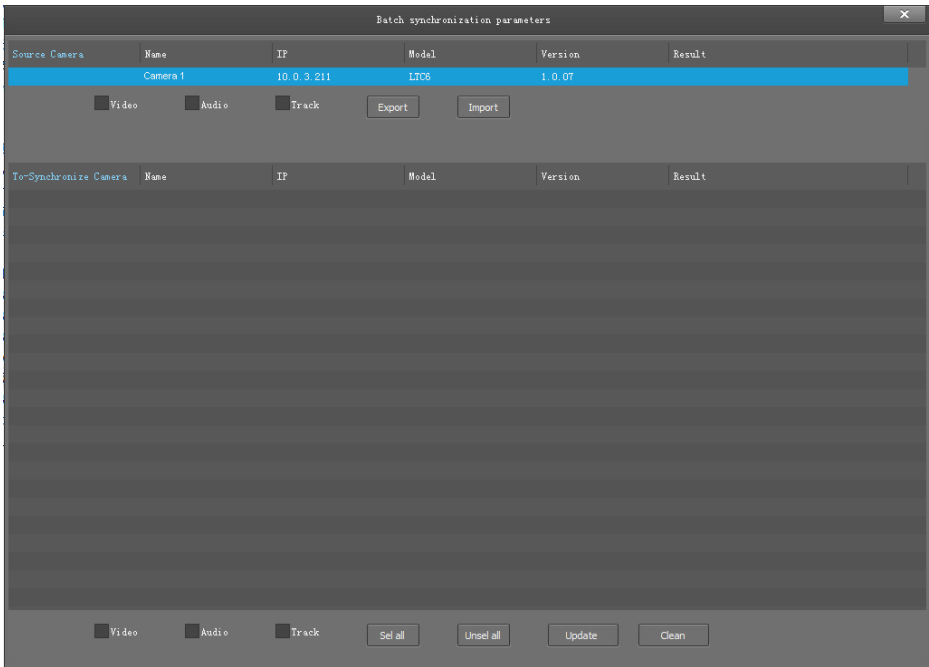

After selecting the same model of the device to be synchronized that is now managed and unchecked, tick any or more of the video parameters, audio parameters, and trace parameters, and when you click the **UP.PM**, the device that you are currently synchronizing will synchronize with the source device parameters.

Parameter import, parameter export: only for source device operations, you can export camera parameters to a file, or you can import parameters from a file into the camera.

Bulk synchronization: Only for synchronous device operations.

## 7.2.8 Preview

Click Main View to get into camera control and preview part as below.

This interface includes three main parts: Device List, Device Control, Video Preview.

- **Device:** It displays all online cameras added to “Device Management”.
- **Device Control:** Get control of the selected camera (camera name in blue).

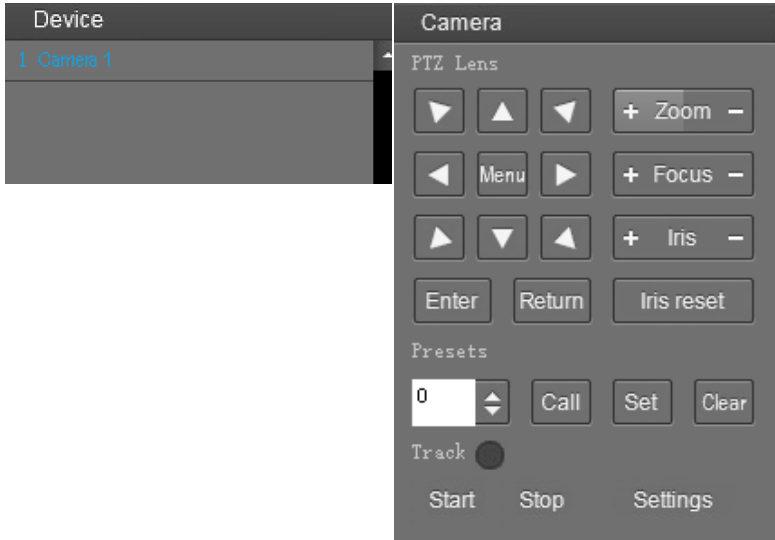

- **Video Preview:** Double click the camera in the list, main camera stream will be displayed in the preview window; or right click the selected camera from the left column to get its main or sub stream video. Video preview mode can be a single video or four videos. When in four video mode, select one of the four videos and then choose the bottom right icon to enlarge this selected video to a big single window.

# 8. MENU SETTINGS

## 8.1 Menu Configuration

<IMAGE>

SHARPNESS	_____	0, 1, 2, 3, 4, 5, 6, 7, 8, 9, 10, 11
BRIGHTNESS	_____	0, 1, 2, 3, 4, 5, 6, 7, 8, 9, 10, 11, 12, 13, 14
CONTRAST	_____	0, 1, 2, 3, 4, 5, 6, 7, 8, 9, 10, 11, 12, 13, 14
GAMMA	_____	0, 1, 2, 3, 4
2DNR LEVEL	_____	0, 1, 2, 3, 4, 5, 6, 7
3DNR LEVEL	_____	0, 1, 2, 3, 4, 5, 6, 7
DRC	_____	0, 1, 2, 3, 4, 5
MIRROR	_____	ON, OFF
FLIP	_____	ON, OFF

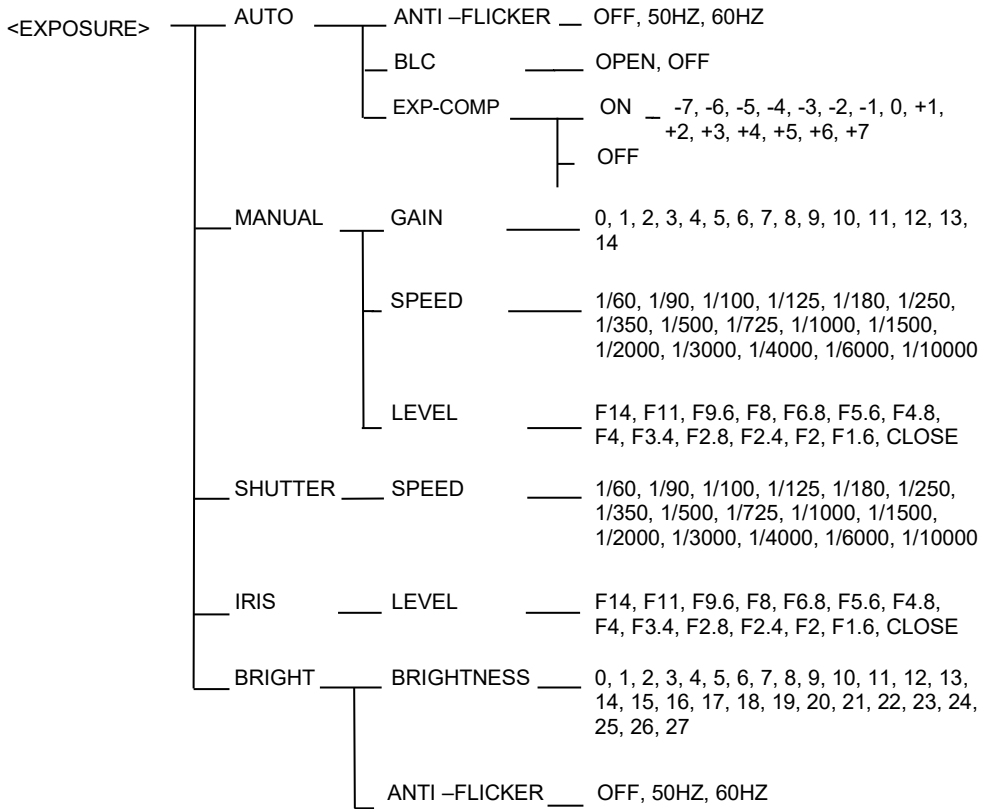

**Note**

The shutter speed in this exposure parameter is a reference value at 30/60 FPS.

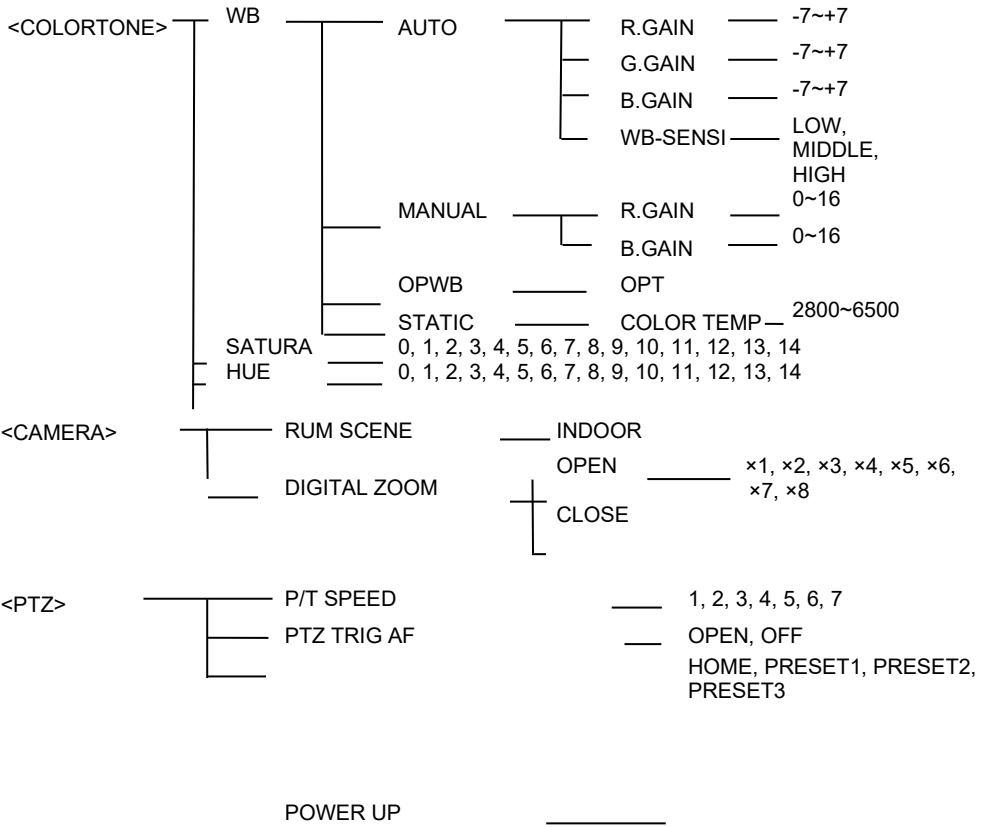

< SYSTEM >	PROTOCOL ADDR	1, 2, 3, 4, 5, 6, 7
	IR ADDR	1, 2, 3
	MOUNT MODE	STAND, CEILING
	PROTOCOL	VISCA, PELCO-P, PELCO-D
	BAUDRATE	2400, 4800, 9600, 38400
	VIDEO FORMAT	4K60, 4K50, 4K30, 4K25, 1080P60, 1080P50, 1080P30, 1080P25, 720P60, 720P50
	LANGUAGE	ENGLISH, CN
	DEFAULTS	CONFIRM
	NETWORK	MODE
		STATICIP, DHCP
		IP ADDRESS
		10.0.3.211
		NET MASK
		255.255.255.0
		GATEWAY
		10.0.3.1
		DNS1
		0.0.0.0
		DNS2
		0.0.0.0

**Note**

The video format is set with the DIP switch.

<DEVICE INFO> — FIRM VERSION

## 8.2 Menu Explanation

1) Press **Menu** button to enter / exit menu.

2) Press **▲▼** button to select options, it is selected when the font is enlarged, press **Enter** to enter the menu.

3) Press **◀▶** to change the value.

Menu	Options	Function Descriptions
<b>Image</b>	Sharpness	Adjust the sharpness of image and image edge sharpness. The higher this number is, the more contrast the detail in the plane of the image will be, making it look clearer.
	Brightness	Adjust the brightness of the image.
	Contrast	Refers to the ratio between the brightest and darkest areas of the image. The greater the ratio, the more gradation levels from black to white will be, thus the richer the color performance, the clearer the image is.
	Gamma	Adjust the permeability of the image.
	2DNR	When the camera is a color image, it is recommended that the user turn off the digital noise reduction function, otherwise the image sharpness will be affected.
	3DNR	By comparing several adjacent images, the noise is automatically filtered out, so that the image noise is significantly reduced, the image is more thorough, and the picture is more pure and delicate. The higher the noise reduction level of the picture, the finer the picture quality and the smaller the jitter feeling. The lower the noise reduction level of the picture, the higher the picture quality and the greater the jitter
	DRC	It refers to the adaptability of the camera to strong light, specifically refers to the variation range of brightness (contrast) and color temperature (contrast).

	Mirror	The camera image is turned 180 ° horizontally.
	Flip	The camera image flips 180 ° vertically.
<b>Exposure</b>	Auto Exposure	According to the ambient brightness prototype to automatically generate exposure parameters and adjust the picture brightness.
	Manual Exposure	The user manually sets the exposure parameters and adjusts the picture brightness.
	Iris Priority	Gain and shutter speed value are adjusted automatically according to working environment; Iris value is adjustable manually.
	Shutter Priority	The aperture is fixed, and the picture brightness is adjusted by adjusting the shutter.
	Bright Priority	The shutter is fixed, and the brightness level of the picture is adjusted by adjusting the analog gain or aperture.
<b>Color Tone</b>	WB Mode	It refers to the working mode of restoring white objects to white under different color temperature environments. It is divided into automatic, manual, one key white balance and other modes.
	WB-Sensi	White balance sensitivity is the threshold of environmental change conditions that trigger white balance convergence. The higher the sensitivity, the easier it is to trigger.
	Saturation	Refers to the purity and brightness of image color, the higher the saturation, the color effect is bright and beautiful.
	Hue	Adjust the overall color of the image.
<b>PTZ</b>	P/T Speed	Set camera's Pan / Tilt speeds.
	PTZ Trig AF	When the camera moves horizontally, vertically and multiplies, it automatically focuses.

	Power UP	This operation is performed when the camera is powered on and doesn't receive the control command.
<b>System</b>	Protocol Address	Change camera's address through menu settings.
	IR Address	Set the IR control address for the camera.
	Mount Mode	The camera image flips 180° vertically and horizontally.
	Protocol	Set the camera control protocol.
	Baud Rate	View and set the current baud rate of the camera.
	Video Format	View and set the current video format of the camera.
	Language	View and set the current language of the camera.
	Defaults	Used to restore all menu parameter settings to factory default settings.
	Network	View and set the current camera network.
<b>Device Info</b>	Firm Version	The version number of the firmware, including the update of the software program.

## 9. TECHNICAL SPECIFICATIONS

Tracking Camera	SDC0G5-B12(N)	SDC0G5-B20(N)	SDC0G5-B30(N)
Image Sensor	1/2.8"4K CMOS, 8.46MP		
Focal Length	f=3.4mm-40.3mm	f=5.2mm ~ 106mm	f=5.2mm ~ 156mm
Iris	F1.8 ~ 3.6	F1.6 ~ F3.5	F1.6 ~ F5
Optical Zoom	12x	20x	30x
HFOV	81°~7.6°	56.5°~2.8°	56.5°~2°
Focus System	Auto / Manual		
White Balance	Auto, Manual, OPWB, Static		
Exposure Control	Auto, Manual, Shutter Priority, Iris Priority, Bright Priority		
S/N	≥50dB		
DNR	2D/3D		
BLC	Support		
Tracking Camera	SDC0G5-B12(N)	SDC0G5-B20(N)	SDC0G5-B30(N)
Image Sensor	N/A	1/2.8"CMOS, 8.46MP	
Focal Length	N/A	f=2.8mm	
HFOV	N/A	94°	
PTZ			
Pan Angle	-130°~+130°		
Tilt Angle	-30°~+90°		
Pan Speed	0.2°/s ~80°/s		
Tilt Speed	0.2°/s~60°/s		
Preset Number	64		
Image Flip	Support		
Interface			
HDMI	1 channel HDMI 2.0 Support 4K60/50/30/25, 1080P60/50/30/25, 720P60/50		

Network	RJ45 (10M/100M), POE 1. Support 4K60/30/25, 1080P30/P25, 720P30/P25, 360P30/P25 2. Image compression H.264, H.265
USB	1 channel USB2.0 1. Support UVC 1.1 2. Image compression H.264/MJPEG; support 4K60, 1080P60/50, 720P60/50.
3G-SDI	1 x 3G-SDI, support 1080P60/50/30/25, 720P60/50
Audio Interface	1 channel LINE IN, 3.5mm audio interface
Control Interface	1 channel RS-232 IN, 1 channel RS-232 OUT
DIP Switch	Rotating DIP switch to set video format
Power	DC12V
<b>General</b>	
Protocol	VISCA/PELCO-D/ PELCO-P
Power Consumption	<18W
Operating Temperature	0°C ~ + 40°C
Storage Temperature	-20°C ~ + 60°C
Operating Humidity	10%RH ~ 90 %RH
Storage Humidity	10%RH ~ 95 %RH
Dimensions (W×H×D)	245mm×146mm×164mm
Weight	< 2kg
Color	Gray

# 10. TROUBLESHOOTING

Problem	Possible Cause	Solution
No action or image after powered on	Power supply failure	Check power supply
	Power adapter damaged	Replace power adapter
	Power cable connection got loosen	Check & reconnect
No self-testing after powered on, or with motor noise	Power cable is too long	Use a shorter cable
	Power adapter damaged	Replace power adapter
	Mechanical failure	Repair
Not controllable from remote controller	Low battery of remote controller	Change battery for remote controller
	Exceeding remote control distance	Control within distance of 8M
After power on, self-test successfully, but not controllable	Wrong address / protocol / baud rate	Check & set again
	Wrong connection or open circuit of RS-232 cable	Check & reconnect
Video loss when pans / tilts / zooms	Power cable is too long	Use a shorter cable
	Power adapter damaged	Replace power adapter
	Video cable not properly connected	Replace with a good video cable
Video captured after connected to digital video interface of a capture device is not good as the video captured after connected directly analog video interface of the capture device	Different video capture devices have different video capturing performance, image quality maybe worse after it has been converted from analog to digital	Consult video capture device supplier for more information