

## SEADA CONFERENCE

### SC13FM Motorised & Retractable Monitor



Simplifying  
Conference Rooms

This SC13FM motorised retractable monitor is one of the latest innovations from SEADA CONFERENCE.

SC13FM offers compact & Ergonomic design which giving adjustable screen viewing angle and large leg room for different users.

This system can be used as a standalone unit in class rooms, offices, receptions etc. In addition, it can operate as a multi units' system with the SEADA paperless conference platform. SEADA conference platform has multiple screens across the table which allows all the participants to have a clear view of the information.

When it is not in use, the monitor can be retracted into the housing beneath the desk. This makes the desk surface tidy as well as putting the monitor in a safe and secure location.

- Ergonomic design
- Fine powder coated surface finish
- Stylish design
- Optimised viewing angle
- Adjustable viewer angle
- HDCP compliance
- Integrated PC power switcher
- Integrated input video sources switcher
- Illuminated capacitive touch buttons
- Compatible with SEADA Multimedia Conference Platform

SEADA CONFERENCE  
Oak Tree Park  
Burnt Meadow Road  
Moons Moat North Industrial Estate,  
Redditch, Worcestershire, UK, B98 9NW  
[www.seada.co.uk](http://www.seada.co.uk)  
Email: [sales@seada.co.uk](mailto:sales@seada.co.uk)  
Phone: +44 (0)1527 584364  
Fax: +44 (0)1527 962998

# Solutions that work for your meeting and conference room.

MOTORIZED & RETRACTABLE MONITORS

From SEADA CONFERENCE

## Specifications

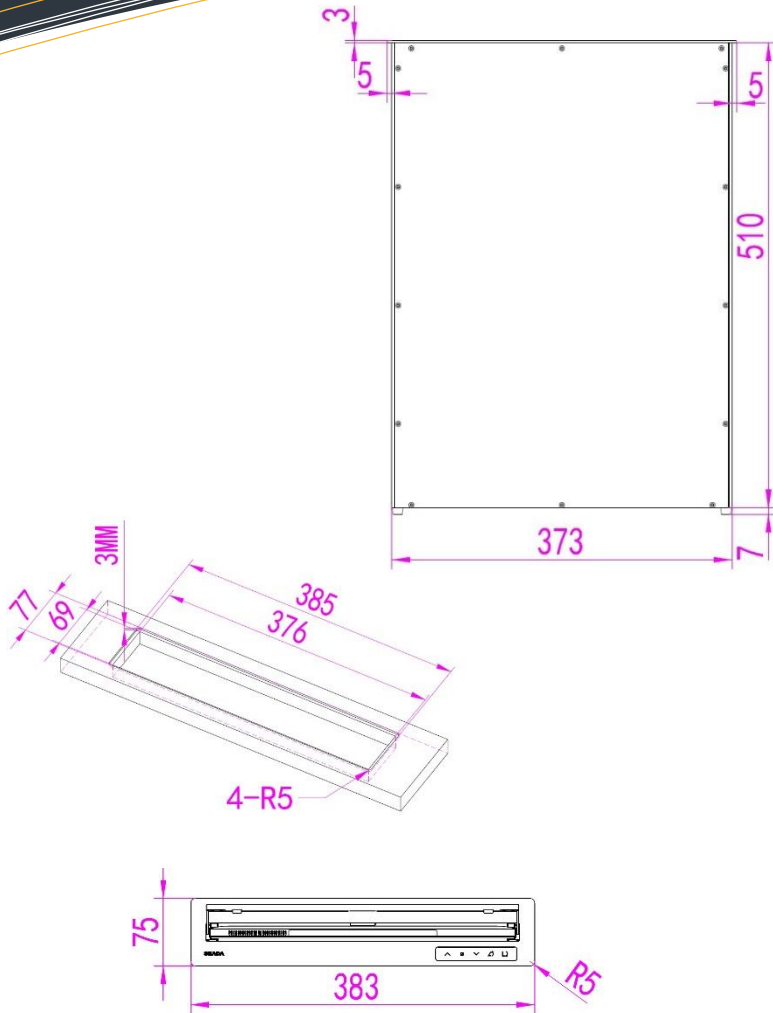

<b>Model</b>	SC13FM
<b>Viewing Angle</b>	0-25°
<b>Control</b>	RS485 & remote control
<b>Screen Size (inches)</b>	13.3
<b>Display Resolution</b>	1920x1080
<b>Touch Screen</b>	Optional
<b>Frame Finish</b>	Anodised Aluminium
<b>System Desktop Frame Size</b>	383mm*75mm*3mm
<b>Housing Desktop Cut Size</b>	376mm* 69mm
<b>System Weight</b>	12kg
<b>System Dimensions(with feet)</b>	520*383mm*75mm
<b>System Shipping Weight</b>	13kg
<b>System Shipping Dimensions</b>	600mm*420mm*210mm
<b>Operating Temperature Range</b>	0~40°
<b>Operating Humidity Range</b>	10%~90% non-condensing
<b>Storage Temperature Range</b>	-20~60°
<b>Storage Temperature Range</b>	10%~90% non-condensing
<b>Parts Warranty</b>	2 Years

### Customization

SEADA CONFERENCE is able to customize our products according to each customer's requirement.